

NODHA®

Quality, Your Value, Our Life

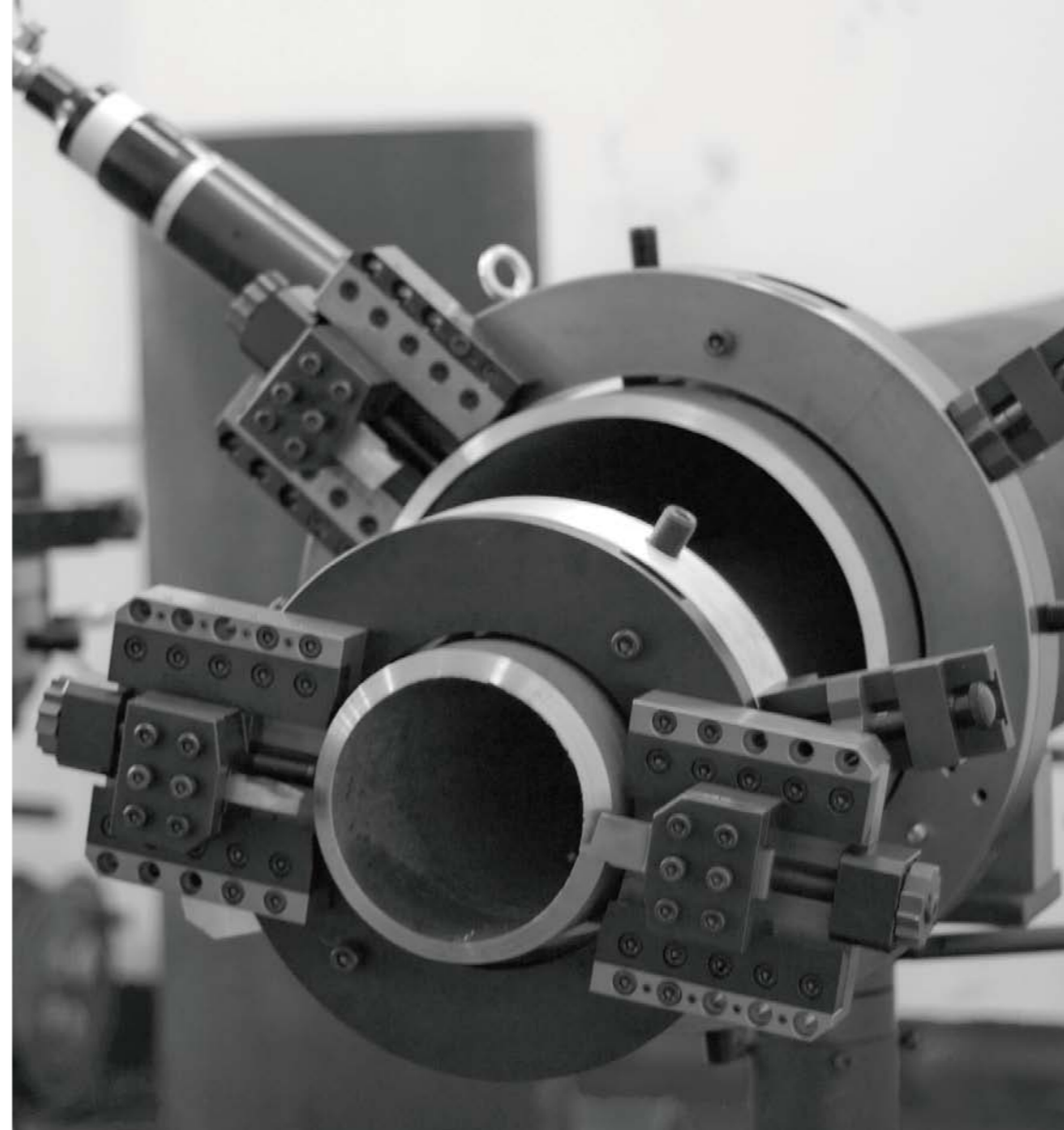

NODHA®

Portable Cutting & Machining Tools

Pipe Cold Cutting & Beveling Machine
Portable Pipe Beveling Machine

YouTube



LinkedIn



facebook



Nodha Industrial Co.,Ltd
Nodha Industrial Technology (Wuxi) Co.,Ltd

Add: 6th Floor, 12nd Building, No. 9 XingYang Road,
Wuxi 214082, China.

Tel: 86 510 8580 9585 Fax: 86 510 8580 8563

E-mail: info@nodha.com sales@nodha.com

Web: www.nodha.com

Distributor:



EN IEC 61000-6-2:2019
EN ISO 12100:2010
EN 13128:2001+A2:2009
EN 60204-1:2018

ISO9001

Due to continuous product development all dimensions and specifications listed above may be subject to alteration without prior notice NODHA accepts no responsibility for any circumstance arising due to any changes that may result.
©NODHA

INDUSTRY 4.0

Victor Series

With the advent of the era of industrial 4.0, the degree of automation is higher and higher. In our field, the application of automatic welding is more and more widely. The beveling for automatic welding required: OD Beveling, Facing and Internal beveling. As the pioneer in China, NODHA is proud to push the "Victor" Series to the market.



1/ Cutter can hold 3 tool bits process in one time. Automatic welding requires OD Beveling, facing and internal beveling. Only 3 side processing finishes in one time can guarantee the precision of beveling. The cutter can install 3 pcs tool bits, meeting the demands.



2/ New expanding structure. New designed expanding structure makes the fix more stable and has a low failure rate.

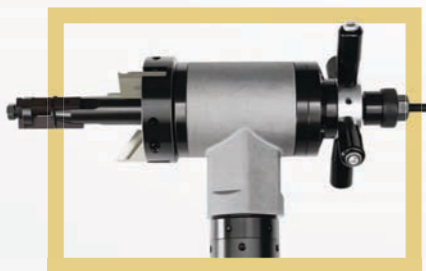

3/ New-design main shaft fixation. There will be a smaller gap of the machine. Performs beveling more smoothly, with less vibration.

V1

Driven Option

V1 P Air Operated
V1 E Electric Operated, NODHA Motor
V1 B Electric Operated, BOSCH Motor

YouTube

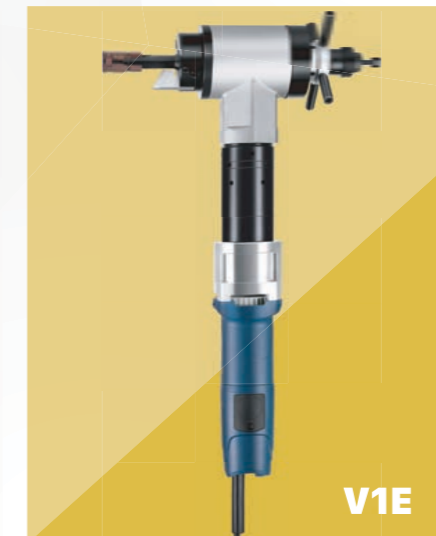

Tool Bits

Standard Tool
V Type Prep.
U Type Prep.
Facing
Inside Beveling
*Consult us for special demand

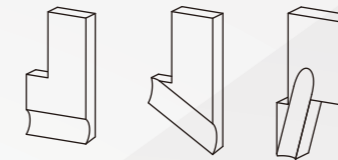

Optional Plastic Box

Standard Supply

Machine with its driven motor
Full set expanding blocks
Hand tools, Manual
Package: Plastic case JC20PC

Specification

Model	V1P	V1E	V1B
Driven	Pneumatic	Electric	Bosch Motor
Power Supply	900L/Min@0.6Mpa	220-240V 1PH 50/60HZ	220-240V 1PH 50/60HZ
Motor Power	1 HP	1000W	1000W
Clamping Range(ID)	15-28mm	15-28mm	15-28mm
Working Range(OD)	1.7"(44mm)	1.7"(44mm)	1.7"(44mm)
Wall Thickness	≤8mm	≤8mm	≤8mm
Rotation Speed	66r/min	52r/min	48r/min
Working Weight	7kg	8kg	8kg
Shipping Weight	13kg	14kg	14kg
Packing Size	590x410x170mm	590x410x170mm	590x410x170mm
Tool Number	2	2	2

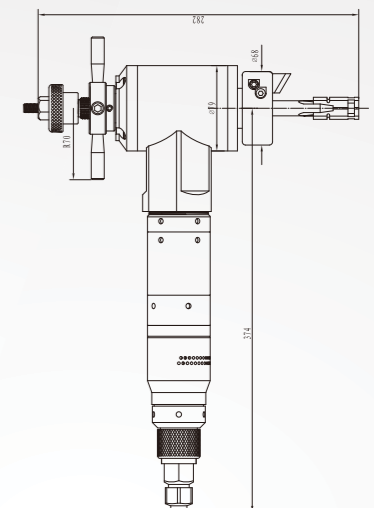

Other Products

Flange Facing Machine



FE305 Flange Facing Machine

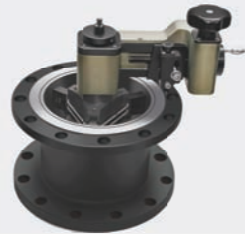

FI355M Flange Facer



FI700 Flange Facing Machine

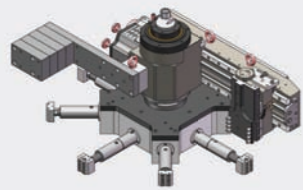

FI1000 Flange Facing Machine

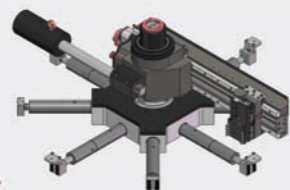

FI1500 Flange Facing Machine

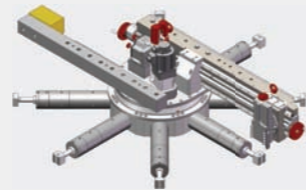

FI2000 Flange Facing Machine

Flange Tool



Hydraulic Flange Spreaders



Collet Style Flange Spreaders



Hydraulic Fixed Flange Alignment Tool



Hydraulic Nut Splitters OX312-series (Single blade)



Hand Pump



Light Weight Hand Pump

Plate Beveling Machine



GBM-6D



GBM-12D



GBM-16D

Plate Edge Milling Machine



GMMA-60S



GMMA-80A



GMMA-80R



GCM-R3TD

Slag Remove Machine

GDM-265D



GDM-3120D



CNC Plate Edge Milling Machine

GMM-VF1500A



GMM-VS/XS

