

NODHA®

Quality, Your Value, Our Life

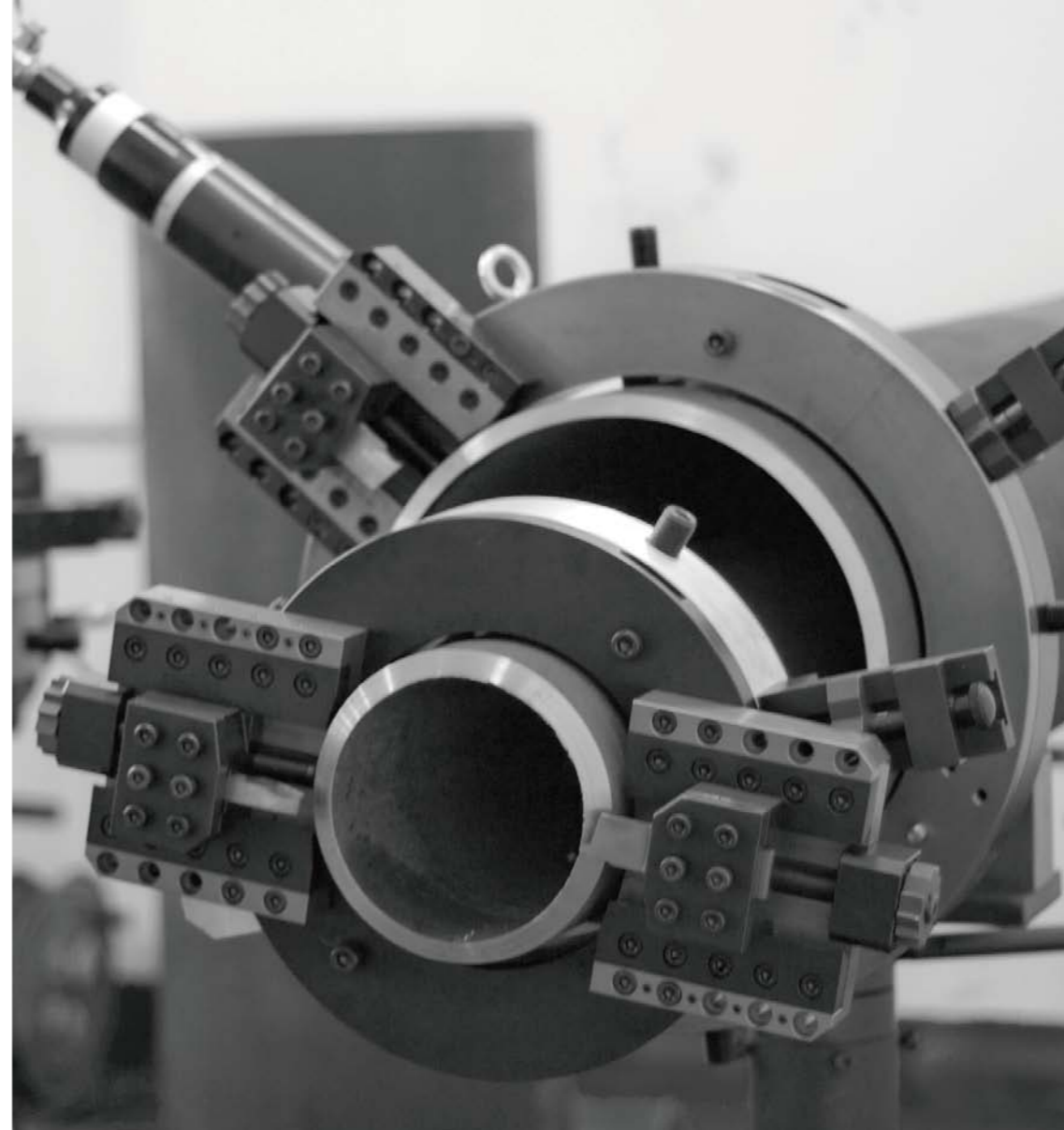

NODHA®

Portable Cutting & Machining Tools

Pipe Cold Cutting & Beveling Machine
Portable Pipe Beveling Machine

YouTube



LinkedIn



facebook



Nodha Industrial Co.,Ltd
Nodha Industrial Technology (Wuxi) Co.,Ltd

Add: 6th Floor, 12nd Building, No. 9 XingYang Road,
Wuxi 214082, China.

Tel: 86 510 8580 9585 Fax: 86 510 8580 8563

E-mail: info@nodha.com sales@nodha.com

Web: www.nodha.com

Distributor:



EN IEC 61000-6-2:2019
EN ISO 12100:2010
EN 13128:2001+A2:2009
EN 60204-1:2018

ISO9001

Due to continuous product development all dimensions and specifications listed above may be subject to alteration without prior notice NODHA accepts no responsibility for any circumstance arising due to any changes that may result.
©NODHA

V8

Driven Option

V8 P Air Operated
V8 E Electric Operated, NODHA Motor



YouTube



V14

Driven Option

V14 P Air Operated
V14 E Electric Operated, NODHA Motor



YouTube



Tool Bits

Standard Tool
V Type Prep.
U Type Prep.
Facing
Inside Beveling
*Consult us for special demand

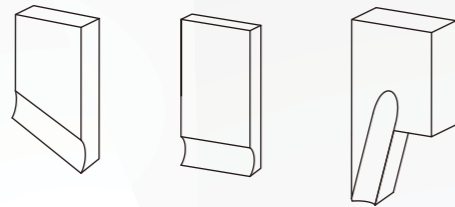

Standard Supply

Machine with its driven motor
Full set expanding blocks
Hand tools, Manual
Package: plywood case

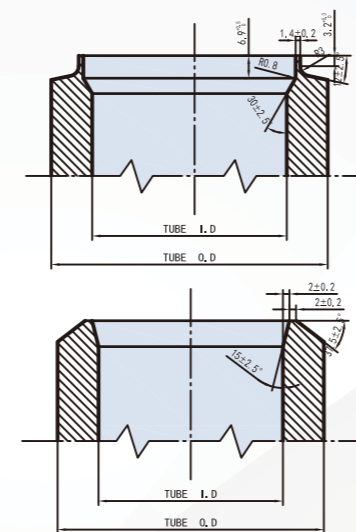

Specification

Model	V8P	V8E
Driven	Pneumatic	Electric
Power Supply	1200L/Min@0.6Mpa	220-240V 1PH 50/60HZ
Motor Power	1.5 HP	1200W
Clamping Range(ID)	65-210mm	65-210mm
Working Range(OD)	8"(219.08mm)	8"(219.08mm)
Wall Thickness	≤20mm	≤20mm
Rotation Speed	28r/min	24r/min
Working Weight	26kg	28kg
Shipping Weight	41kg	45kg
Packing Size	730X310X340mm	830x310x340mm
Tool Number	3	3

Tool Bits

Standard Tool
V Type Prep.
U Type Prep.
Facing
Inside Beveling
*Consult us for special demand

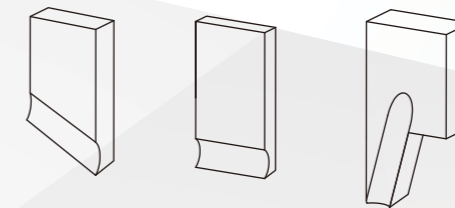

Specification

Model	V14P	V14E
Driven	Pneumatic	Electric
Power Supply	1200L/Min@0.6Mpa	220-240V 1PH 50/60HZ
Motor Power	1.5 HP	1500W
Clamping Range(ID)	145-340mm	145-340mm
Working Range(OD)	14"(355.6mm)	14"(355.6mm)
Wall Thickness	≤20mm	≤20mm
Rotation Speed	18r/min	20r/min
Working Weight	46kg	48kg
Shipping Weight	V14P2 : 71kgs V14P3 : 73kgs	V14E2 : 75kgs V14E3 : 78kgs
Packing Size	V14P2 : 840x460x330mm V14P3 : 840x420x450mm	V14E2 : 940x460x300mm V14E3 : 940x460x450mm
Tool Number	2 or 3	2 or 3

Standard Supply

Machine with its driven motor
Full set expanding blocks
Hand tools, Manual
Package: plywood case



Other Products

Flange Facing Machine



FE305 Flange Facing Machine

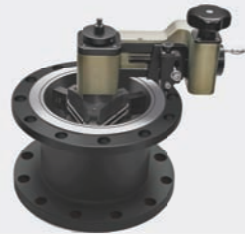

FI355M Flange Facer

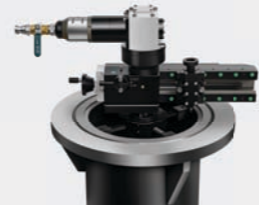

FI700 Flange Facing Machine

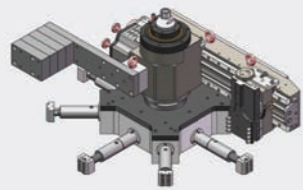

FI1000 Flange Facing Machine

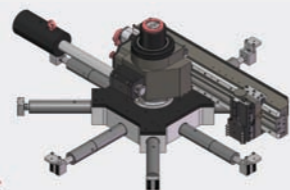

FI1500 Flange Facing Machine

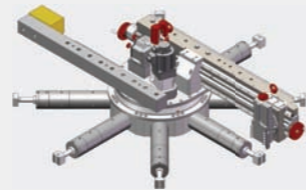

FI2000 Flange Facing Machine

Flange Tool



Hydraulic Flange Spreaders



Collet Style Flange Spreaders



Hydraulic Fixed Flange Alignment Tool



Hydraulic Nut Splitters OX312-series (Single blade)



Hand Pump



Light Weight Hand Pump

Plate Beveling Machine



GBM-6D



GBM-12D



GBM-16D

Plate Edge Milling Machine



GMMA-60S



GMMA-80A



GMMA-80R



GCM-R3TD

Slag Remove Machine

GDM-265D



GDM-3120D



CNC Plate Edge Milling Machine

GMM-VF1500A



GMM-VS/XS

