

NODHA®

Quality, Your Value, Our Life

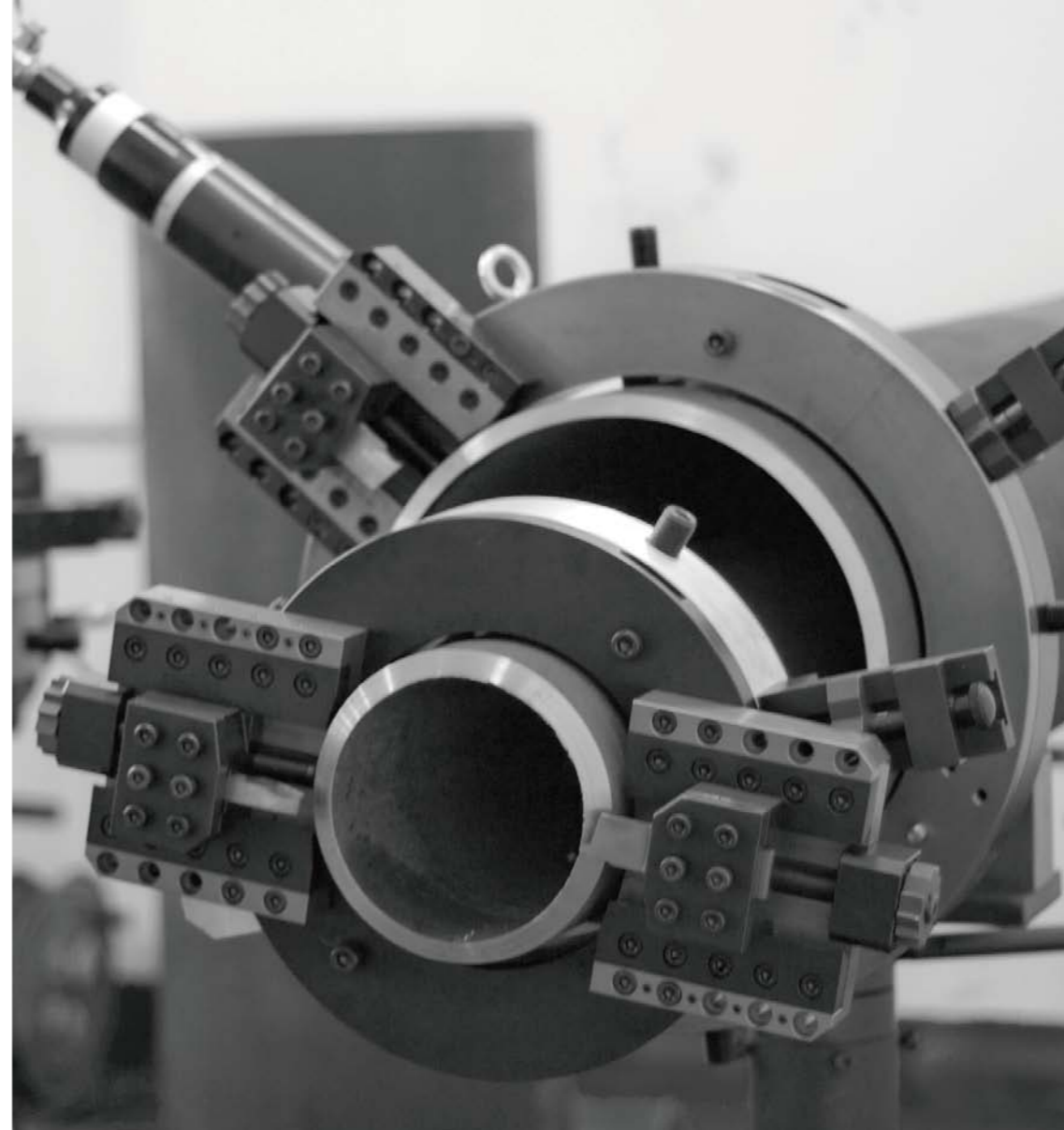

NODHA®

Portable Cutting & Machining Tools

Pipe Cold Cutting & Beveling Machine
Portable Pipe Beveling Machine

YouTube



LinkedIn



facebook



Nodha Industrial Co.,Ltd
Nodha Industrial Technology (Wuxi) Co.,Ltd

Add: 6th Floor, 12nd Building, No. 9 XingYang Road,
Wuxi 214082, China.

Tel: 86 510 8580 9585 Fax: 86 510 8580 8563

E-mail: info@nodha.com sales@nodha.com

Web: www.nodha.com

Distributor:



EN IEC 61000-6-2:2019
EN ISO 12100:2010
EN 13128:2001+A2:2009
EN 60204-1:2018

ISO9001

Due to continuous product development all dimensions and specifications listed above may be subject to alteration without prior notice NODHA accepts no responsibility for any circumstance arising due to any changes that may result.
©NODHA

V3

YouTube



Driven Option

V3 P Air Operated
V3 E Electric Operated, NODHA Motor
V3 B Electric Operated, BOSCH Motor



V3P



V3E



V3B

Tool Bits

Standard Tool
V Type Prep.
U Type Prep.
Facing
Inside Beveling

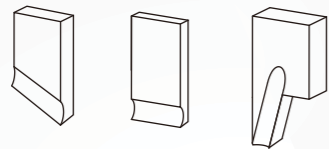

*Consult us for special demand



Optional Plastic Box

Standard Supply

Machine with its driven motor
Full set expanding blocks
Hand tools, Manual
Package: Plastic case JC20PC

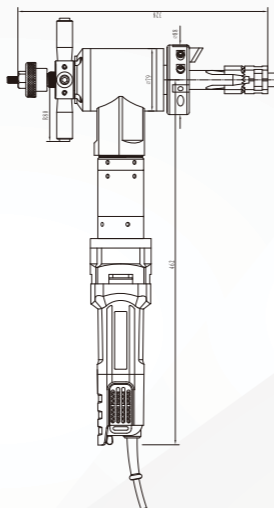

Specification

Model	V3P	V3E	V3B
Driven	Pneumatic	Electric	Bosch Motor
Power Supply	900L/Min@0.6Mpa	220-240V 1PH 50/60HZ	220-240V 1PH 50/60HZ
Motor Power	1 HP	1000W	1000W
Clamping Range(ID)	25-76mm	25-76mm	25-76mm
Working Range(OD)	3"(88.9mm)	3"(88.9mm)	3"(88.9mm)
Wall Thickness	≤15mm	≤15mm	≤15mm
Rotation Speed	66r/min	52r/min	48r/min
Working Weight	8.5kg	9kg	9kg
Shipping Weight	15kg	16kg	16kg
Packing Size	590x410x170mm	590x410x170mm	590x410x170mm
Tool Number	3	3	3

V6

YouTube



Driven Option

V6 P Air Operated
V6 E Electric Operated, NODHA Motor
V6 B Electric Operated, BOSCH Motor



V6P



V6E



V6B

Tool Bits

Standard Tool
V Type Prep.
U Type Prep.
Facing
Inside Beveling

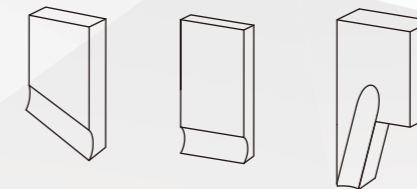

*Consult us for special demand

Standard Supply

Machine with its driven motor
Full set expanding blocks
Hand tools, Manual
Package: plywood case

Specification

Model	V6P	V6E	V6B
Driven	Pneumatic	Electric	Bosch Motor
Power Supply	900L/Min@0.6Mpa	220-240V 1PH 50/60HZ	220-240V 1PH 50/60HZ
Motor Power	1 HP	1050W	1000W
Clamping Range(ID)	60-159mm	60-159mm	60-159mm
Working Range(OD)	6"(168.28mm)	6"(168.28mm)	6"(168.28mm)
Wall Thickness	≤20mm	≤20mm	≤20mm
Rotation Speed	40r/min	36r/min	38r/min
Working Weight	16kg	17kg	17kg
Shipping Weight	30kg	33kg	33kg
Packing Size	680x550x260mm	680x550x260mm	680x550x260mm
Tool Number	3	3	3

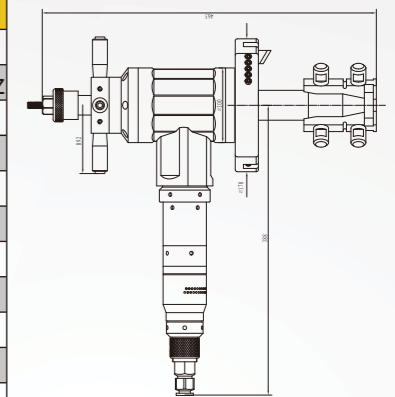

Other Products

Flange Facing Machine



FE305 Flange Facing Machine

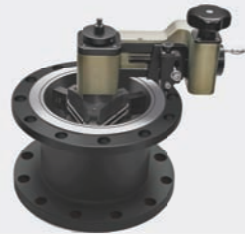

FI355M Flange Facer

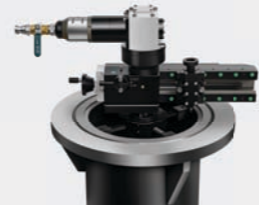

FI700 Flange Facing Machine

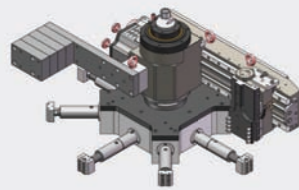

FI1000 Flange Facing Machine

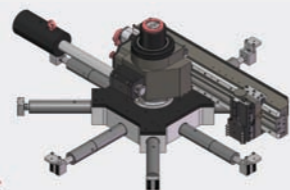

FI1500 Flange Facing Machine

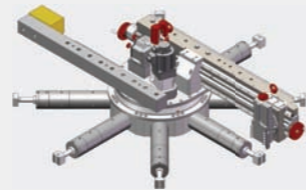

FI2000 Flange Facing Machine

Flange Tool



Hydraulic Flange Spreaders



Collet Style Flange Spreaders



Hydraulic Fixed Flange Alignment Tool



Hydraulic Nut Splitters OX312-series (Single blade)



Hand Pump



Light Weight Hand Pump

Plate Beveling Machine



GBM-6D



GBM-12D



GBM-16D

Plate Edge Milling Machine



GMMA-60S



GMMA-80A



GMMA-80R



GCM-R3TD

Slag Remove Machine

GDM-265D



GDM-3120D



CNC Plate Edge Milling Machine

GMM-VF1500A



GMM-VS/XS

