

NODHA®

Quality, Your Value, Our Life

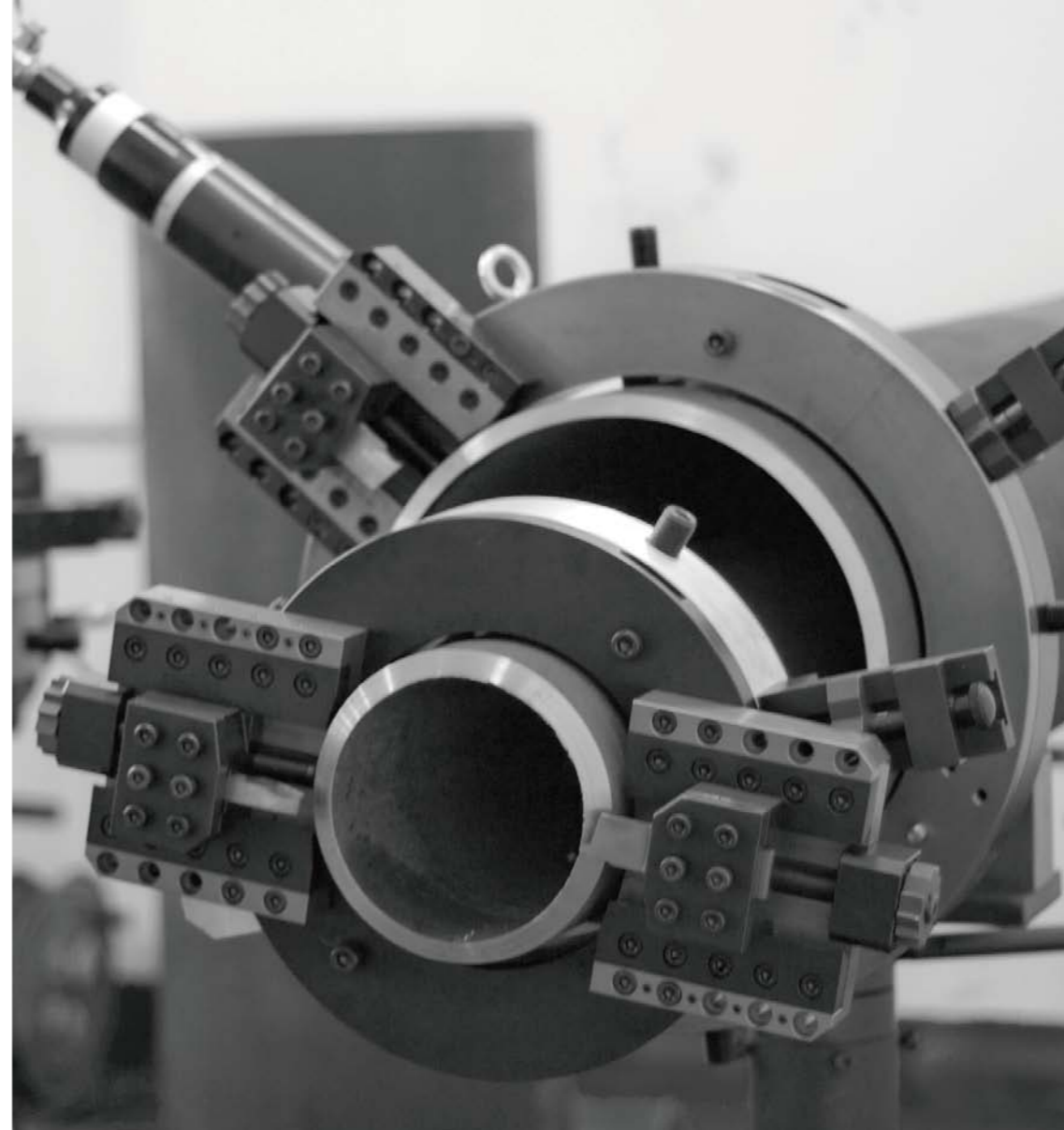

NODHA®

Portable Cutting & Machining Tools

Pipe Cold Cutting & Beveling Machine
Portable Pipe Beveling Machine

YouTube



LinkedIn



facebook



Nodha Industrial Co.,Ltd
Nodha Industrial Technology (Wuxi) Co.,Ltd

Add: 6th Floor, 12nd Building, No. 9 XingYang Road,
Wuxi 214082, China.

Tel: 86 510 8580 9585 Fax: 86 510 8580 8563

E-mail: info@nodha.com sales@nodha.com

Web: www.nodha.com

Distributor:



EN IEC 61000-6-2:2019
EN ISO 12100:2010
EN 13128:2001+A2:2009
EN 60204-1:2018

ISO9001

Due to continuous product development all dimensions and specifications listed above may be subject to alteration without prior notice NODHA accepts no responsibility for any circumstance arising due to any changes that may result.
©NODHA

Heat Exchanger Tube Facing Machine 2021 NEW Product

TF Series tube fast facing machine is idea for tubes of heat exchanger, performs facing the ends of tubing and tube sheet bores in preparation for welding and finish squaring.

Engineered for safety and ease of use, equips an air locking system with special cylinder. Compact designed tool holder can install 2 inserts.

For most material including: Ferrous, non-ferrous, stainless steel, exotic alloys steel, duplex, inconel and titanium alloy steel.

Most apply to facing the different lengths tube of the tubesheet, air clamping, level type feed structure, can greatly improve the work efficiency.

YouTube



Specification

Model	TF16
Working Range	ID12mm - OD16mm
Clamping Range	ID12-14mm
Wall thickness	<3.5mm
Driven	Pneumatic
Power	1.47HP
Power Supply	900-1000L/Min@0.6Mpa
Feed stroke	25mm
Feed type	Lever-type
Rotation Speed	220rpm
Working weight	9 kgs
Shipping weight	30 kgs
Shipping Dimensions	680x650x275mm

Model	TF40
Working Range	ID14mm - OD40mm
Clamping Range	ID14-34mm
Wall thickness	<2.5mm
Driven	Pneumatic
Power	1.47HP
Power Supply	900-1000L/Min@0.6Mpa
Feed stroke	25mm
Feed type	Lever-type
Rotation Speed	220rpm
Working weight	9 kgs
Shipping weight	30 kgs
Shipping Dimensions	680x650x275mm



Features

Aluminium 7075 body, light weight and rigidity

Self-centering air clamping automatically

Lever type feed structure, easy and fast feed/back the tool

10 sizes collet and 4 tool head, cover wider range

Carbide inserts apply for most material

Adjustable length control device

Durable transport/storage case

Optional Lifting balancer make the higher efficiency

Dimension Figure

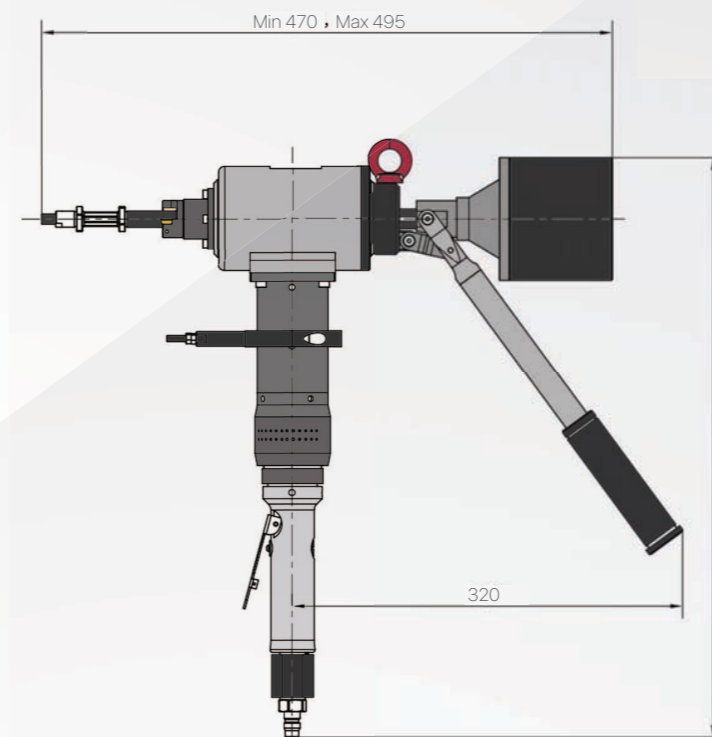

TF16 Toolholder and Collet Specification

Toolholder Part No.	Tube ID Range	Application
TH1124	Dia.11.5-24.1mm	TF16
Collets Part No.	Collet OD	Tube ID
MC01	11.2mm	12mm
MC02	12.2mm	13mm
MC03	13.2mm	14mm

TF40 Toolholder and Collet Specification

Toolholder Part No.	Tube ID Range	Application
TH1326	Dia. 13.7-26.3mm	TF40
TH1528	Dia.15.7-28.3mm	TF40
TH2134	Dia. 21.7-34.3mm	TF40
TH2740	Dia. 27.7-40.3mm	TF40
Collets Part No.	Collet OD	Tube ID
C01	13.5mm	14mm
C02	14.5mm	15mm
C03	16.5mm	17mm
C04	18.2mm	19mm
C05	19.2mm	20mm
C06	20.2mm	21mm
C07	25.2mm	26mm
C08	27.2mm	28mm
C09	31.2mm	32mm
C10	33.2mm	34mm



Standard Supply

TF16	TF40
Main Body-c/w Motor	Main Body-c/w Motor
Toolholder - 1 size	Toolholder - 4 sizes
Spring Collets - 10 sizes	Spring Collets - 10 sizes
Cutting tips - 10 pcs	Cutting tips - 10 pcs
T8 Torx screwdriver - 1	T8 Torx screwdriver - 1
Metric L-Key 3/4/5mm	Metric L-Key 3/4/5mm
Wrench - 1	Wrench - 1
FLR unit	FLR unit
Air Hose connection	Air Hose connection
Air motor lubricating oil	Air motor lubricating oil
Manual	Manual
Optional- Lifting balancer	Optional- Lifting balancer
Storage / Shipping case	Storage / Shipping case

Application



Other Products

Flange Facing Machine



FE305 Flange Facing Machine



FI355M Flange Facer



FI700 Flange Facing Machine

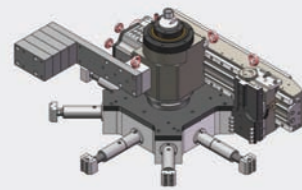

FI1000 Flange Facing Machine

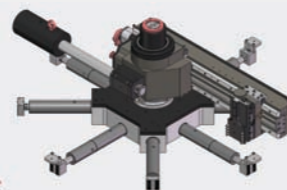

FI1500 Flange Facing Machine

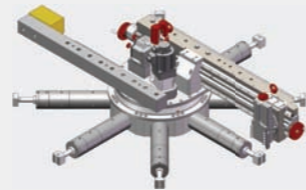

FI2000 Flange Facing Machine

Flange Tool



Hydraulic Flange Spreaders



Collet Style Flange Spreaders



Hydraulic Fixed Flange Alignment Tool



Hydraulic Nut Splitters OX312-series (Single blade)



Hand Pump



Light Weight Hand Pump

Plate Beveling Machine



GBM-6D



GBM-12D



GBM-16D

Plate Edge Milling Machine



GMMA-60S



GMMA-80A



GMMA-80R



GCM-R3TD

Slag Remove Machine

GDM-265D



GDM-3120D



CNC Plate Edge Milling Machine

GMM-VF1500A



GMM-VS/XS

