

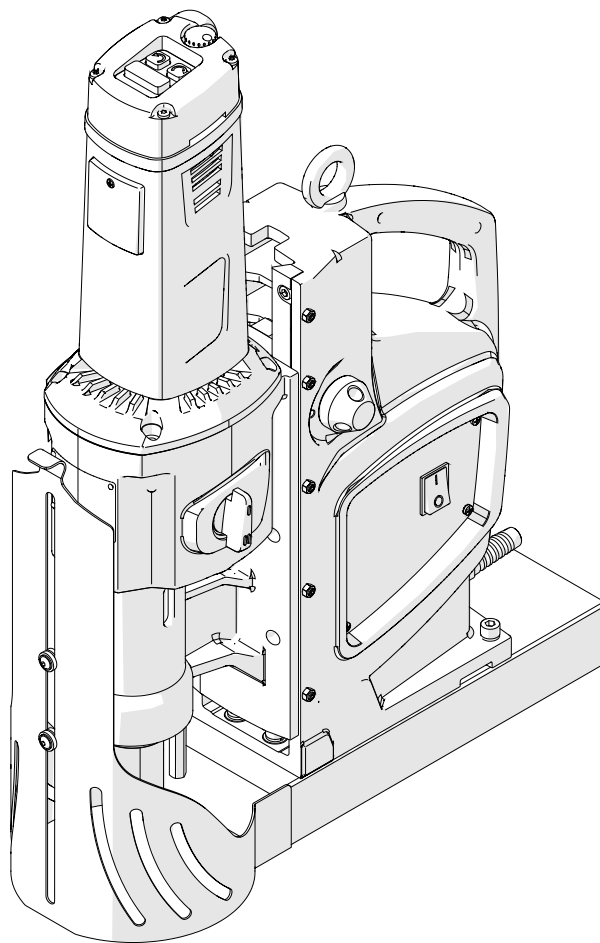

Parts list

Drilling machine with electromagnetic base **FE150 RLX**



Fe Powertools BV, Jac.P.Thijsseweg 16, 2408 ER Alphen aan den Rijn

The Netherlands tel. + 31 172 474727

www.fepowertools.com e-mail: info@fepowertools.com



Fe Powertools BV, Jac.P.Thijsseweg 16, 2408 ER Alphen aan den Rijn
The Netherlands tel. + 31 172 474727
www.fepowertools.com e-mail: info@fepowertools.com

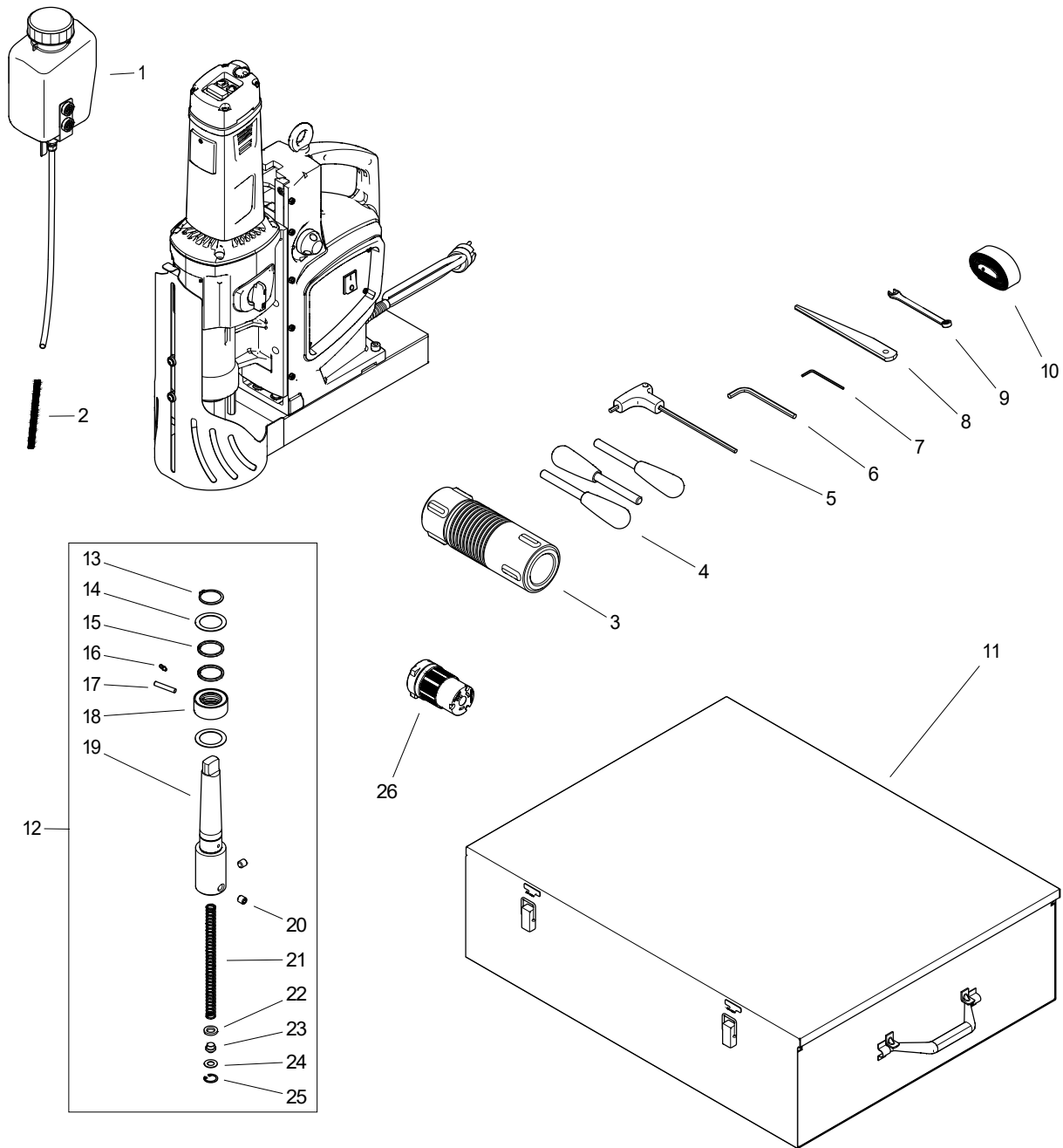

ITEM	PART NUMBER	DESCRIPTION	Q-TY
1	UKL-0563-07-00-00-0	COOLANT BOOTLE ASSY	1
2	OSL-0399-17-00-00-0	SAFETY SPRING	1
3	OPK-000001	TOOL CAN	1
4	DZW-0178-09-00-00-0	SPOKE HANDLE ASSY	3
5	KLC-000037	5 MM HEX WRENCH WITH HANDLE	1
6	KLC-000009	6 MM HEX WRENCH	1
7	KLC-000005	2.5 MM HEX WRENCH	1
8	KLN-0103-00-00-00-0	WEDGE MT3	1
9	KLC-000003	8 MM COMBINATION WRENCH	1
10	PAS-000008	SAFETY STRAP 500	1
11	SKR-0583-12-00-00-0	METAL BOX ASSY	1
12	UCW-0583-14-00-00-0	ARBOR ASSY AMT4-C-19 4-4	1
13	PRS-000023	EXTERNAL RETAINING RING 32z	1
14	PDK-0583-13-03-00-0	WASHER	2

ITEM	PART NUMBER	DESCRIPTION	Q-TY
15	PRS-000299	O-RING 32.2x3	2
16	KNC-0234-00-10-00-0	CONNECTOR 4x11.5	1
17	PRT-0151-06-13-00-2	ROD L=35	1
18	TLJ-0583-13-02-00-0	COOLING SLEEVE	1
19	KRP-0583-14-01-00-0	ARBOR BODY AMT4-C-19 4-4	1
20	WKR-000032	HEX SOCKET SET SCREW WITH FLAT POINT M10x10	2
21	SPR-0563-20-02-00-0	SPRING	1
22	USZ-0220-00-04-00-0	WASHER	1
23	WYP-0154-00-02-00-0	PLUNGER	1
24	PDK-0139-00-04-00-0	WASHER 18.8x10x1	1
25	PRS-000009	INTERNAL RETAINING RING 19w	1
26	ZLC-000299	LOCKING COUPLING (115V ONLY)	1

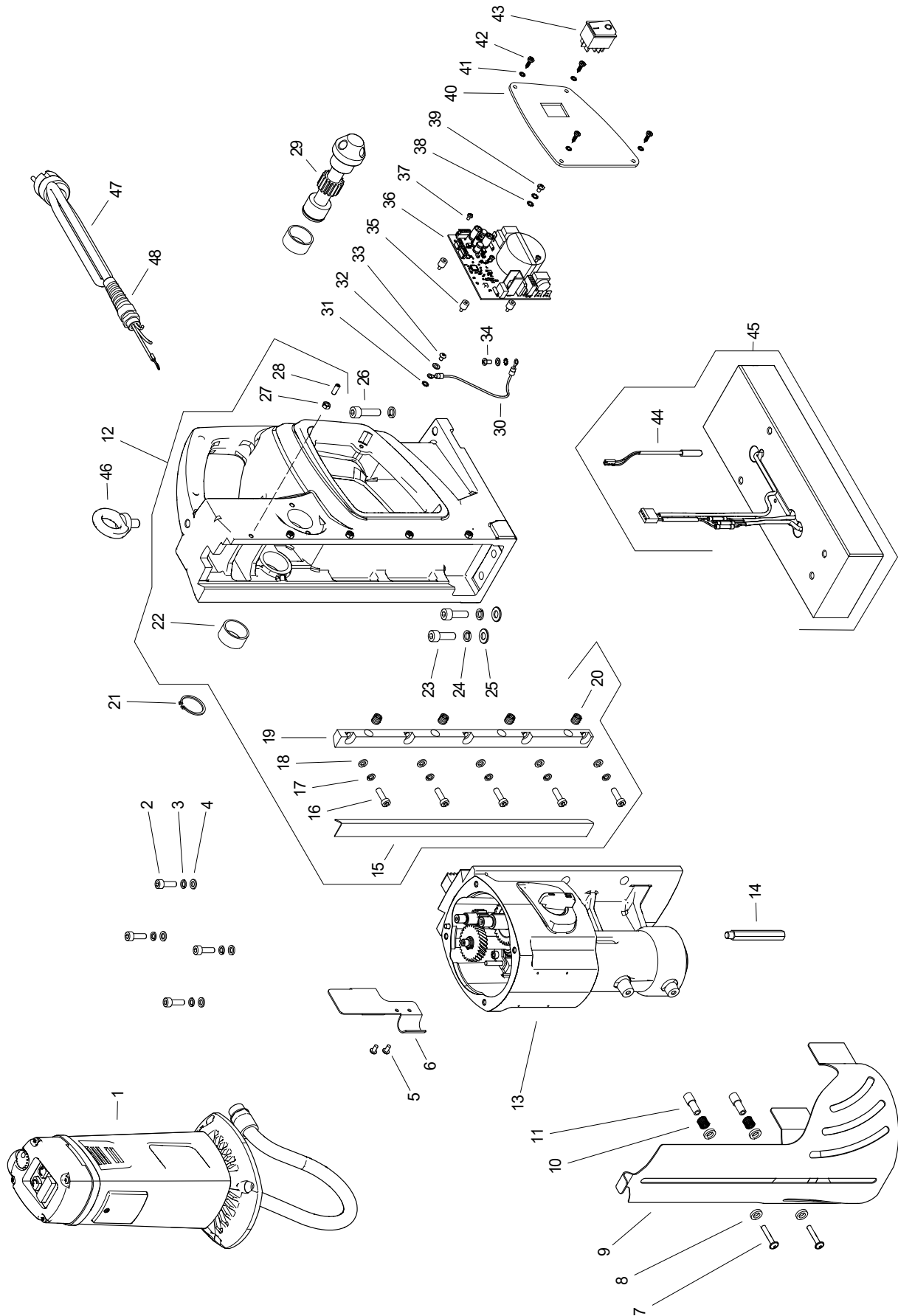

ITEM	PART NUMBER	DESCRIPTION	Q-TY
1	SLN-0583-01-00-00-0	MOTOR - 115V	1
1	SLN-0583-01-00-00-1	MOTOR - 230V	1

This document is protected by copyrights.
 Copying, using, or distributing without permission of FE Powertools is prohibited.

ITEM	PART NUMBER	DESCRIPTION	Q-TY
2	SRB-000114	HEX SOCKET HEAD CAP SCREW M6x20	4
3	PDK-000046	SPRING WASHER 6.1	4
4	PDK-000136	SMALL ROUND WASHER 6.4	4
5	WKR-000193	CROSS RECESSED PAN HEAD SCREW M4x8	2
6	NKD-0563-06-00-00-0	COOLANT BOOTLE BRACKET	1
7	WKR-000563	HEX SOCKET ROUND HEAD SCREW WITH FLANGE M5x40	2
8	PDK-000151	NYLON WASHER 8.1x14x3	4
9	OSL-0583-08-00-00-1	GUARD	1
10	SPR-000030	PUSH SPRING	2
11	TLJ-0583-18-00-00-0	SLEEVE	2
12	KRP-0583-03-01-00-0	BODY ASSY	1
13	ZSP-0583-02-00-00-0	GEARBOX ASSY	1
14	PLC-0143-03-06-00-3	STOP ROD	1
15	LST-0583-03-01-03-0	GIB	1
16	SRB-000304	LOW HEAD SOCKET CAP SCREW M6x20	5
17	PDK-000046	SPRING WASHER 6.1	5
18	PDK-000136	SMALL ROUND WASHER 6.4	5
19	LST-0583-03-01-02-0	ADJUSTABLE GIB	1
20	SPR-000043	SPRING 1.6x8x14.5	4
21	PRS-000019	EXTERNAL RETAINING RING 28z	1
22	TLJ-000010	SELF-LUBRICATING SLEEVE 28x32x16	2
23	SRB-000153	HEX SOCKET HEAD CAP SCREW M8x25	2
24	PDK-000051	SPRING WASHER 8.2	4
25	PDK-000022	ROUND WASHER 8.4	2
26	SRB-000155	HEX SOCKET HEAD CAP SCREW M8x30	2
27	NKR-000015	HEX NUT M5	5
28	WKR-000410	HEX SOCKET SET SCREW WITH FLAT POINT M5x14	5
29	WLK-0563-14-00-00-0	PINION SHAFT	1
30	WZK-0563-03-10-00-0	SAFETY WIRE SET (W3)	1
31	PDK-000166	EXTERNAL TOOTH LOCK WASHER 4.3	2
32	PDK-000015	ROUND WASHER 4.3	2
33	WKR-000553	HEX SOCKET BUTTON HEAD SCREW M4x6	2
34	WKR-000193	CROSS RECESSED PAN HEAD SCREW M4x8	1
35	WBR-000004	DAMPER	3
36	MDL-0583-80-03-00-0	MAGNETIC BASE MODULE - 115V (BB1)	1
36	MDL-0583-80-04-00-0	MAGNETIC BASE MODULE - 230V (BB1)	1
37	WKR-000180	CROSS RECESSED PAN HEAD SCREW M3x5	3
38	PDK-000060	EXTERNAL TOOTH LOCK WASHER 4.3	2
39	WKR-000192	CROSS RECESSED PAN HEAD SCREW M4x6	1
40	MSK-0583-99-00-00-0	PANEL PLATE	1
41	PDK-000161	EXTERNAL TOOTH LOCK WASHER 3.7	4
42	WKR-000415	CROSS RECESSED PAN HEAD SELF-TAPPING SCREW 3.5x13	4
43	PNK-000013	MAGNET SWITCH	1
44	WZK-0563-03-02-02-0	REED WIRES SET (W15)	1
45	PDS-0583-03-02-00-0	ELECTROMAGNETIC BASE ASSY (230V)	1
45	PDS-0583-03-02-00-1	ELECTROMAGNETIC BASE ASSY (115V)	1
46	SRB-000299	EYE BOLT M10	1
47	PWD-0563-16-01-00-0	POWER CORD 120V WITH STRAIN RELIEF ASSY (US)	1
47	PWD-0563-16-02-00-0	POWER CORD 230V WITH STRAIN RELIEF ASSY (EU)	1
47	PWD-0563-16-03-00-0	POWER CORD 230V WITH STRAIN RELIEF ASSY (AU)	1
47	PWD-0563-16-04-00-0	POWER CORD 230V WITH STRAIN RELIEF ASSY (INDIA)	1
47	PWD-0563-16-05-00-0	POWER CORD 230V WITH STRAIN RELIEF ASSY (UK)	1
48	DLW-000008	CABLE GLAND WITH STRAIN RELIEF PG13.5	1
49*	PWD-0563-10-00-00-0	GROUNDING WIRE SET	1

*not shown in the drawing

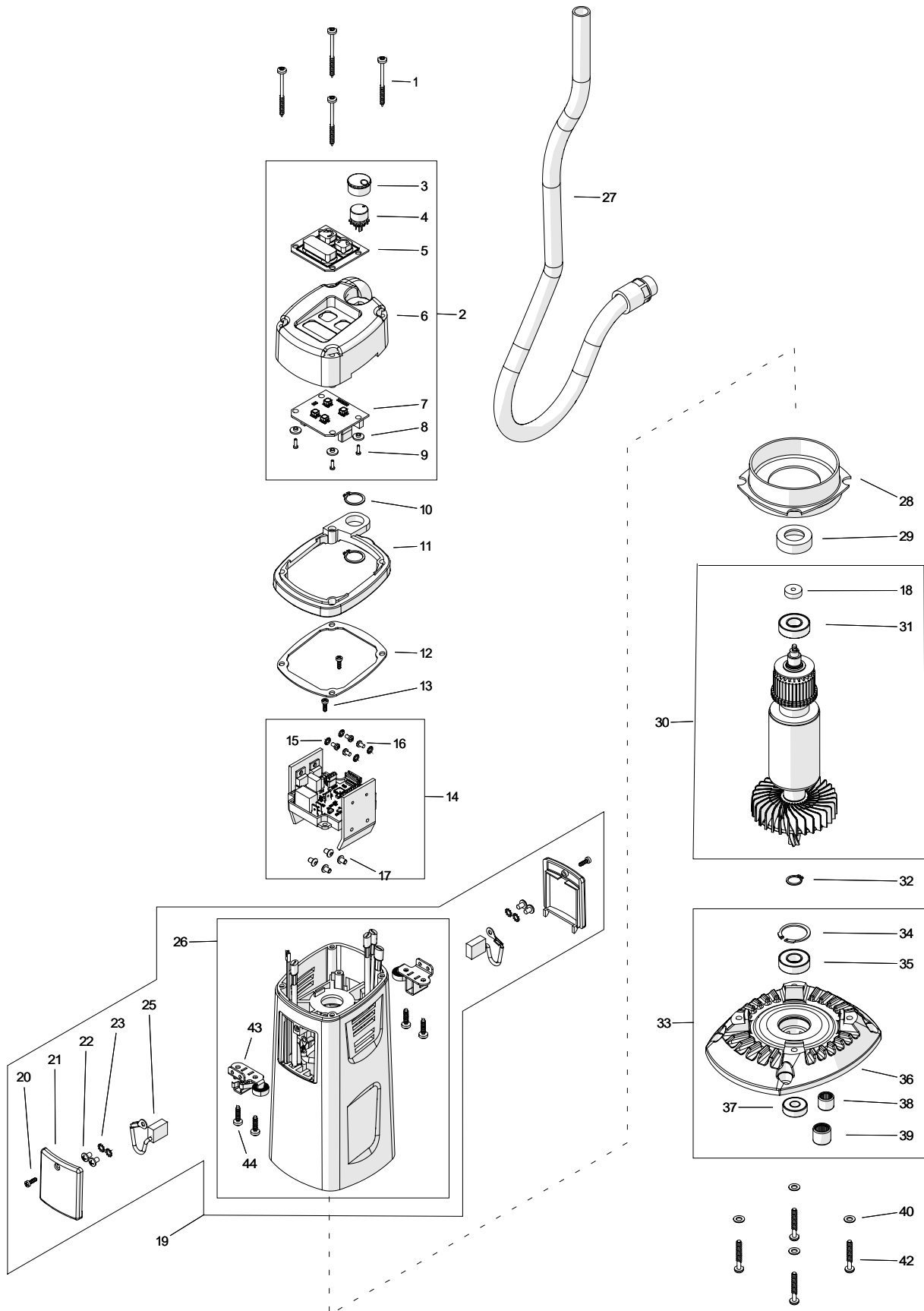

ITEM	PART NUMBER	DESCRIPTION	Q-TY
1	WKR-000529	TORX PAN HEAD SCREW 4x50	4
2	PKR-0563-01-06-00-0	STATOR COVER ASSY	1
3	PKT-0563-01-06-04-0	POTENTIOMETER KNOB	1
4	PTN-000039	POTENTIOMETER	1
5	OSL-0563-01-06-02-0	BUTTON COVER	1
6	PKR-0563-01-06-01-0	STATOR COVER	1
7	OBW-0563-80-05-01-0	KEYBOARD MODULE (OB1)	1
8	TLJ-000151	INSULATION SLEEVE 2.6x3.9	4
9	WKR-000458	SCREW FOR PLASTIC 2.2x8	4
10	PRS-000238	EXTERNAL RETAINING RING 16z	2
11	SYG-0563-01-05-01-0	SIGNALLER	1
12	MDL-0563-80-04-00-0	SIGNALING MODULE (LB1)	1
13	WKR-000506	SCREW FOR PLASTIC 3x10	2
14	ZSP-0583-17-00-00-0	ELECTRONIC CONTROLLER SET ASSY - 115V (MB1)	1
14	ZSP-0583-17-00-00-1	ELECTRONIC CONTROLLER SET ASSY - 230V (MB1)	1
15	PDK-000058	EXTERNAL TOOTH LOCK WASHER 3.2	4
16	WKR-000180	CROSS RECESSED PAN HEAD SCREW M3x5	4
17	WKR-000292	HEX SOCKET BUTTON HEAD SCREW M4x6	4
18	IMP-000002	PULSE GENERATOR	1
19	OBD-0563-99-02-00-0	MOTOR COVER WITH STATOR ASSY – 115V	1
19	OBD-0563-99-02-00-1	MOTOR COVER WITH STATOR ASSY – 230V	1
20	WKR-000506	SCREW FOR PLASTIC 3x10	2
21	PKR-0563-01-09-00-0	BRUSH COVER	2
22	WKR-000192	CROSS RECESSED PAN HEAD SCREW M4x6	4
23	PDK-000060	EXTERNAL TOOTH LOCK WASHER 4.3	4
25	SCZ-000035	BRUSH - 115V	2
25	SCZ-000036	BRUSH - 230V	2
26	OBD-0563-99-01-00-0	STATOR HOUSING ASSY – 115V	1
26	OBD-0563-99-01-00-1	STATOR HOUSING ASSY – 230V	1
27	WZK-0583-01-08-00-0	MOTOR WIRE SET	1
28	OBD-0563-01-07-00-0	FAN COVER	1
29	WKL-000046	BEARING INSERT	1
30	WRN-0563-99-00-00-0	ROTOR ASSY - 115V	1
30	WRN-0563-99-00-00-1	ROTOR ASSY - 230V	1
31	LOZ-000158	BALL BEARING 12x28x8	1
32	PRS-000003	EXTERNAL RETAINING RING 12z	1
33	PKR-0583-01-02-00-0	GEARBOX COVER ASSY	1
34	PRS-000356	INTERNAL RETAINING RING 28w	1
35	LOZ-000025	BALL BEARING 12x28x8	1
36	PKR-0583-01-02-01-1	GEARBOX COVER	1
37	LOZ-000053	BALL BEARING 8x22x7	1
38	LOZ-000162	NEEDLE BEARING 10x14x12	1
39	LOZ-000176	NEEDLE BEARING 12x16x14	1
40	PDK-000017	ROUND WASHER 5.3	4
42	WKR-000525	TORX PAN HEAD TAPPING SCREW 5x30	4
43	SCT-000013	BRUSH HOLDER	2
44	WKR-000300	SCREW FOR PLASTIC 4x16	4
45*	WZK-0563-01-06-07-0	POTENTIOMETER WIRE SET (W6)	1
46*	WZK-0563-01-11-00-0	LED WIRE SET (W4)	1
47*	WZK-0563-01-12-00-0	CONTROLLER WIRE SET (W2)	1
48*	PWD-0563-01-13-00-0	BRUSH HOLDER WIRE (W14)	1
49*	PWD-0563-09-02-00-0	CONTROLLER WIRE SET (W12)	1

This document is protected by copyrights.

Copying, using, or distributing without permission of FE Powertools is prohibited.

ITEM	PART NUMBER	DESCRIPTION	Q-TY
50*	PWD-0563-09-03-00-0	CONTROLLER WIRE SET (W13)	1

*not shown in the drawing

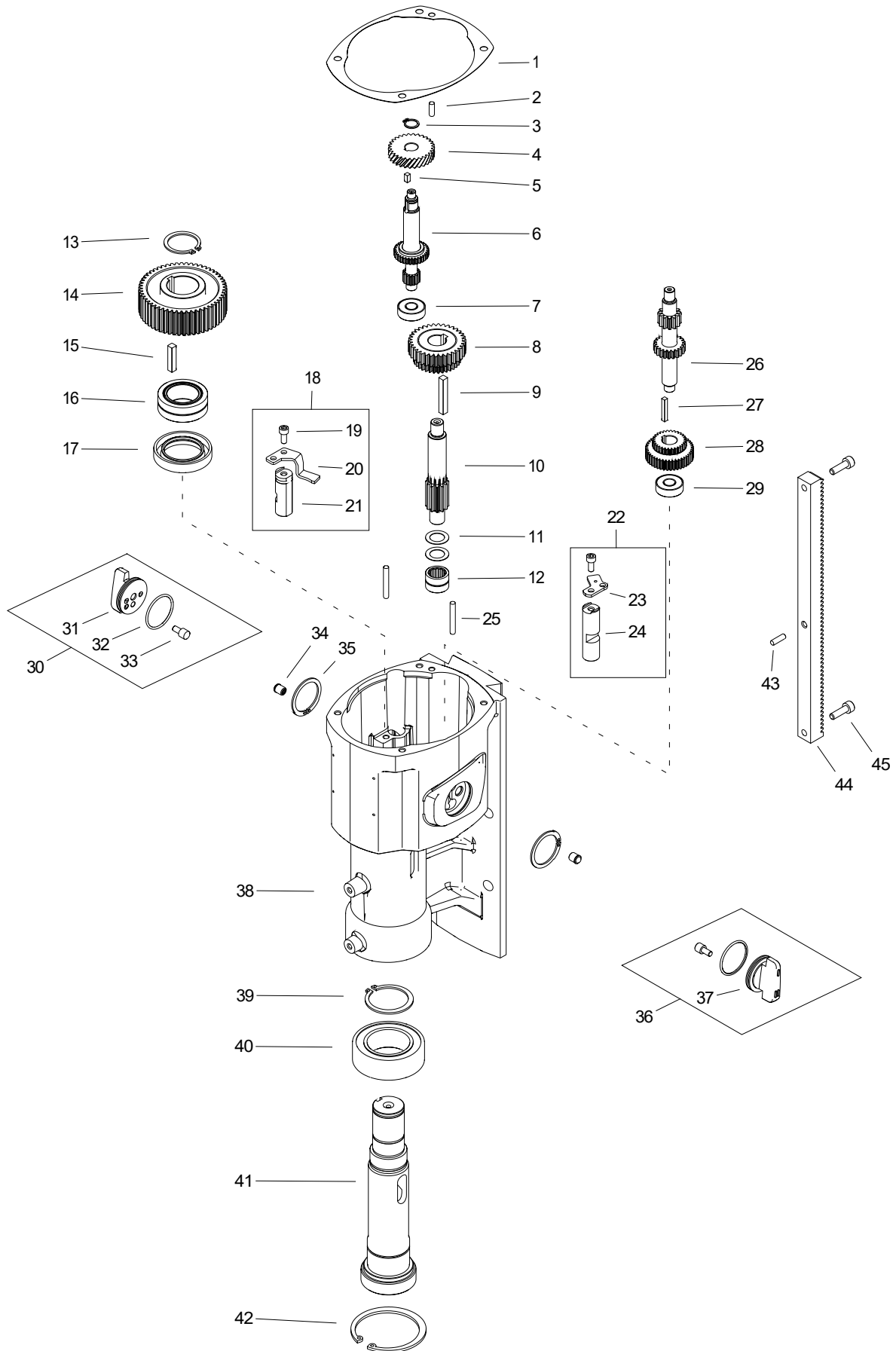

ITEM	PART NUMBER	DESCRIPTION	Q-TY
1	USZ-0583-02-15-00-0	BODY SEAL	1
2	KLK-000046	DOWEL PIN 5n6x14	1
3	PRS-000003	EXTERNAL RETAINING RING 12z	1
4	KOL-0563-02-03-02-0	GEAR z29	1
5	WPS-0563-02-23-00-0	PARALLEL KEY 4x4x8	1
6	WLK-0583-02-02-00-0	PINION SHAFT ASSY	1
7	LOZ-000161	BALL BEARING 10x26x8	1
8	KOL-0583-02-04-00-0	GEAR z34	1
9	WPS-0563-02-19-00-1	KEY 6x6x40	1
10	WLK-0583-02-07-00-0	PINION SHAFT z12	1
11	PDK-0563-02-22-00-0	WASHER 14x22x0.5	2
12	LOZ-000175	NEEDLE BEARING 14x22x16	1
13	PRS-000021	EXTERNAL RETAINING RING 30z	1
14	KOL-0583-02-06-00-0	GEAR z54	1
15	WPS-0583-02-13-00-1	KEY 6x6x28	1
16	LOZ-000178	NEEDLE BEARING 30x47x17	1
17	PRS-000077	SEAL 35x55x10	1
18	WDZ-0583-02-10-00-0	SHORT SLIPPER ASSY	1
19	SRB-000078	HEX SOCKET HEAD CAP SCREW M5x12	2
20	ZCZ-0583-02-10-02-0	SHORT SLIPPER BRACKET	1
21	WLK-0583-02-10-01-0	SHORT SLIPPER SHAFT	1
22	WDZ-0583-02-11-00-0	LONG SLIPPER ASSY	1
23	ZCZ-0583-02-11-01-0	LONG SLIPPER BRACKET	1
24	WLK-0563-02-11-01-0	LONG SLIPPER SHAFT	1
25	KLK-000111	DOWEL PIN 5n6x36	2
26	WLK-0583-02-08-00-0	PINION SHAFT z12	1
27	WPS-0563-02-20-00-1	KEY 4x4x25	1
28	KOL-0583-02-03-00-0	GEAR z27, z43	1
29	LOZ-000161	BALL BEARING 10x26x8	1
30	PKT-0583-02-14-00-0	SHORT SHIFT KNOB ASSY	1
31	KRP-0583-02-14-01-0	SHORT SHIFT KNOB	1
32	PRS-000327	OS-RING 32x2	2
33	KLK-0599-02-09-02-0	KNOB PIN	2
34	ZTR-000001	BALL LOCK 8	2
35	PRS-000346	INTERNAL RETAINING RING 36w	2
36	PKT-0563-02-13-00-0	LONG SHIFT KNOB ASSY	1
37	KRP-0563-02-13-01-1	LONG SHIFT KNOB	1
38	KRP-0583-02-01-01-1	GEARBOX BODY	1
39	PRS-000139	EXTERNAL RETAINING RING 40z	1
40	LOZ-000179	BALL BEARING 40x68x21	1
41	WRZ-0583-02-05-11-0	SPINDLE	1
42	PRS-000244	INTERNAL RETAINING RING 68w	1
43	KLK-000047	DOWEL PIN 5n6x16	1
44	LST-0583-02-09-00-0	GEAR RACK	1
45	SRB-000114	HEX SOCKET HEAD CAP SCREW M6x20	2
46*	SMR-000001	GREASE	0,8

*not shown in the drawing

WIRING DIAGRAM

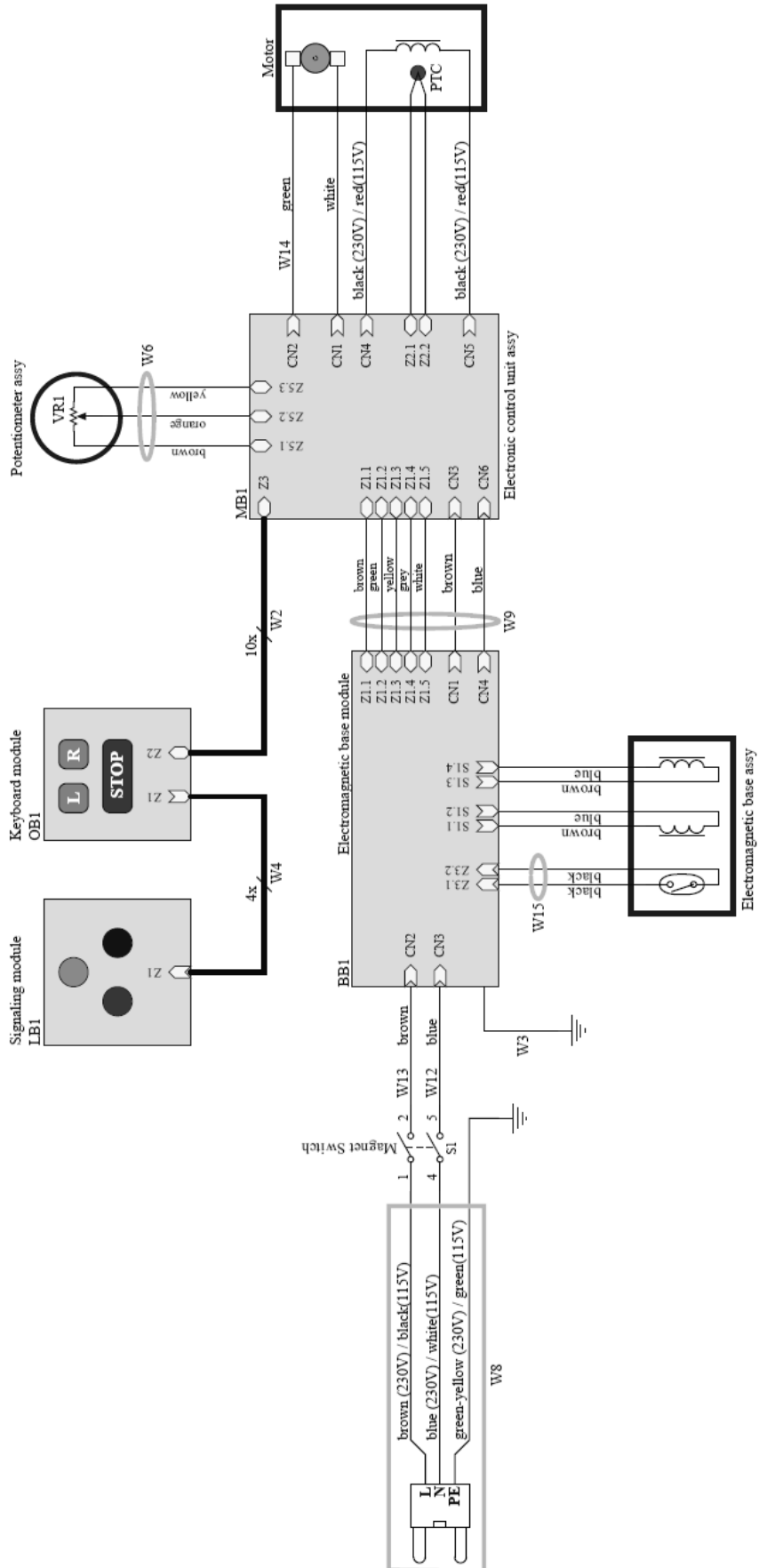

ELECTRONIC CONTROL UNIT ASSY

