

## FE 150 R/L X MAGNETIC DRILLING MACHINE

*Left/Right option*



Motor power:	2300 Watt
Spindle:	Morse conus 4 – 31,75MM
Hole cutters:	12MM – 150MM
Twist drills:	max. 47 MM
Tap max.:	M42
Motor speed :	(( 1)55-85,(2)100-150, (3)200-300, (4) 350-520
Stroke:	260MM
Max. cutting depth:	100MM
Clamping force magnet :	2550 KG
Weight:	31KG
Height:	634 – 894 MM
Voltage:	220V-240V, 50-60Hz
Magnet size:	lxbxh 315x105x49MM

- Automatic cooling system
- Automatic speed stabilization
- Torque protection
- Overload protection
- Overheating protection
- Full wave control electronics
- Magnet indicator

max. Ø 150 mm	max. Ø 47 mm	max. M42

### MEASUREMENTS

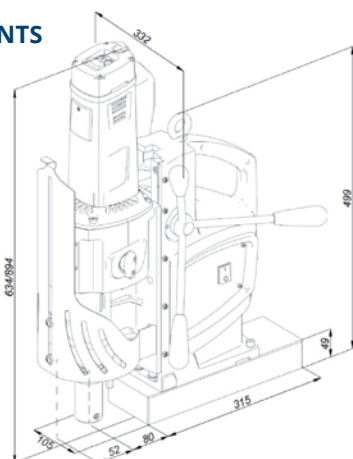

230 V  
110 V



### STANDARD DELIVERY OF MAGNETIC DRILLING MACHINE FE 150 R/L X CONTAINS:

- |                                    |                 |
|------------------------------------|-----------------|
| Magnetic drilling machine          | tooling set     |
| including automatic cooling system | operator manual |
| MT4 arbor 19MM ( 32MM optional )   | steel Metal box |
| safety guard                       |                 |