

## FE 50 X MAGNETIC DRILLING MACHINE





**FE 50 X magnetic drilling machine**, the all-rounder. The exchangeable Morse taper 2 makes this magnetic drilling machine an all-round machine for all drilling purposes. This machine is supplied with auto coolant system cleverly mounted on top of the machine. This magnetic drilling machine is powered by a strong 1150 watt Eibenstock motor.

All our machines can be supplied in 110 Volt as well as in 230 Volt

Motor power:	1150 Watt
Spindle:	Morse taper 2 – 19 mm (3/4") Weldon
Hole cutter/annular cutter	(short 30mm) ø12mm-ø50mm (2")
Hole cutter/annular cutter	(long 55mm) ø12mm-ø50mm (2")
Twist drills:	Ø 23 mm (7/8")
RPM:	I 250 min-1 – II 450 min-1
Stroke:	160 mm (6.29")
Weight:	13 Kgs (26.8 Lbs)
Magnet power:	1500 kgg

Auto-feed control system (dynamic feed speed adjustment)

	
max. ø 50 mm	max. ø 23 mm

### MEASUREMENTS

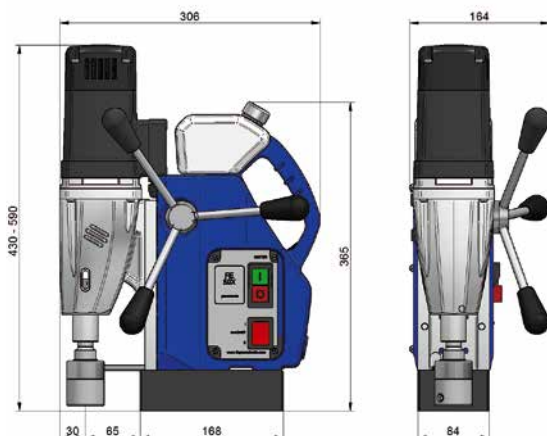

### STANDARD DELIVERY OF MAGNETIC DRILLING MACHINE FE 50 X CONTAINS:

- |                                   |                                 |
|-----------------------------------|---------------------------------|
| 1 pilot pin FEPP 75(Ø 6.35×79 mm) | 1 safety chain                  |
| 1 Hex key 4                       | 1 user manual/safety guidelines |
| 1 PP carrying case                | Cutting oil 0.25L               |