

2.5. COMPLETE DRAWINGS

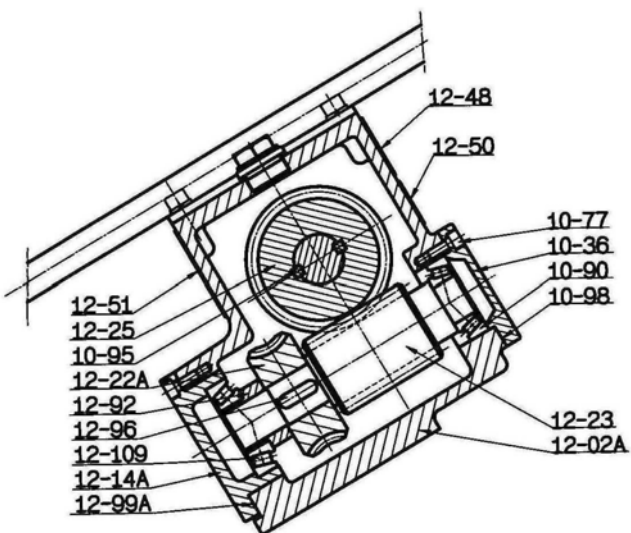

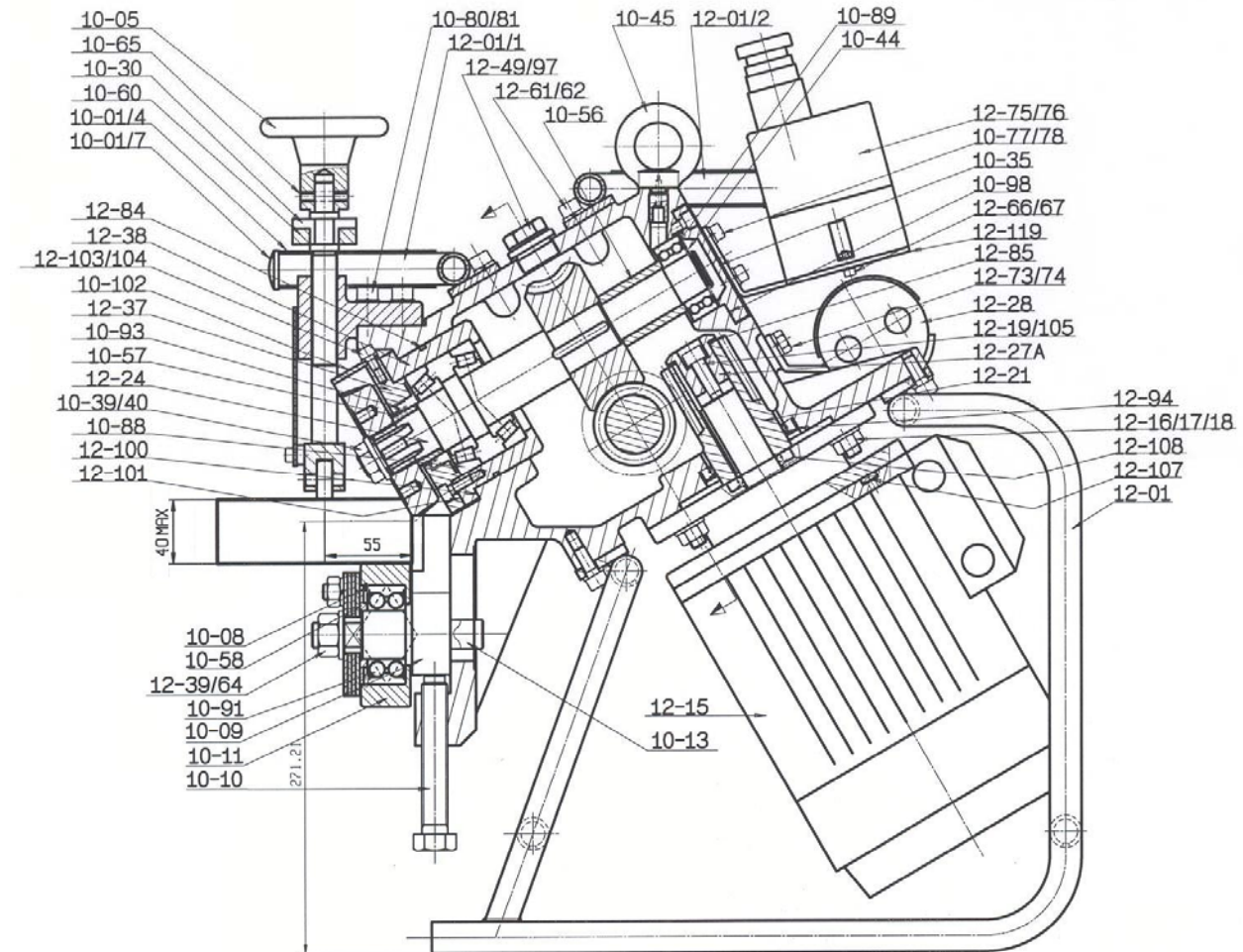

MILLING CUTTER
EXTRACTION TOOL

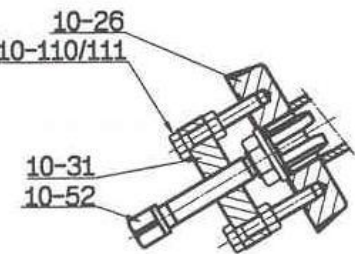
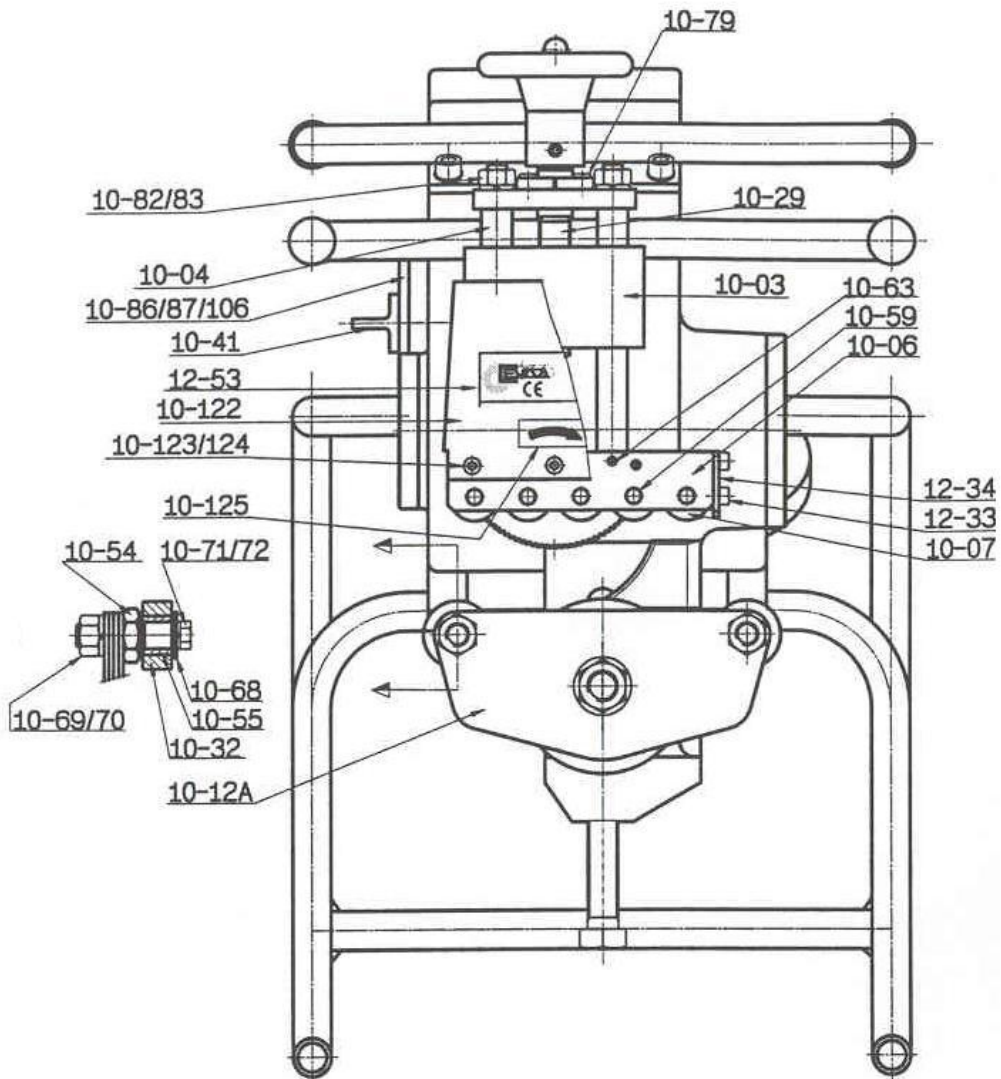
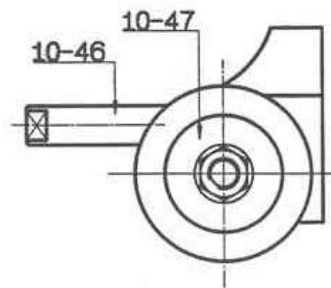

DEVICE TO BEVEL TUBES



7. SPARE PARTS AND ACCESSORIES

7.1. LIST OF SPARE PARTS OF THE BEVELLING MACHINE «CEVISA» CHP-12

REF.	DESIGNATION	REF.	DESIGNATION
12-01	Support frame and handles	12-43	Bevel adjustment scale
12-02A	Housing	10-45	Lifting eye bolt
12-03	Support nut	10-46	Tube bevelling shaft
10-04	Guide cylinders(2 p.)	10-47	Tube bevelling washer
10-05	Adjustment wheel	12-49	Oil filler cap
10-06	Roller-holder support	10-54	Secondary pulley shaft (2 p.)
10-07	Support rollers (5 p.)	10-55	Bushing (2 p.)
10-09	Vertical slide	10-56	Bearing Sp. Bushing
10-10	Adjustment spindle	10-57	Cutter sp. Bushing
10-11	Guide pulley	10-58	Pulley sp. Bushing
10-12A	Secondary pulley support	10-60	Mobile support
10-13	Lockscrew	10-68	Washer (2 p.)
12-14A	Side cover	12-75	Electric box
12-15	3 H.P. motor	10-86	Washer
12-21	Input worm gear	10-88	Bearing N° 30.207 (2 p.)
12-22A	Worm crown gear	10-89	Bearing N° 4.205
12-23	Wormshaft	10-90	Bearing N° 30.205
12-24	Main shaft	10-91	Bearing N° 3.206
12-25	Worm crown gear	12-92	Spacer Bushing
10-26	Milling cutter	10-93	Oil seal 35X47X6 (2 P.)
12-27A	Bushing	12-94	Oil seal 50X68X8/8,5
12-28	Switchbox	10-98	Seal (2 p.)
10-29	Adjustment spindle	12-99A	Seal
10-30	Spindle f. Bushing	12-100	Seal
10-31	Cutter extraction tool	12-101	Seal
10-32	Secondary pulley (2 p.)	10-102	Milling cutter protector
10-35	Blank cover	12-108	Oil seal 25X47X7
10-36	Blank cover	12-109	Bearing N° 30.206
12-37	Front cover	12-119	Electric box support
12-38	Bearing holder bushing	10-122	Protection
10-41	Reversing-switch	10-123	Bushing

7.2. ACCESSORIES TO BE DELIVERED WITH THE MACHINE

- 3 milling cutters, reference 1026 (one fitted on machine).
- 1 milling cutter extraction tool.
- 1 device to bevel tubes.
- Set of spanners : 12-13 mm., 18-19 mm. and 24-26 mm.
- Set of "Allen" keys : 5 mm. and 6 mm.