

Hand-held beveling machine

# SMA 60 BPV-46.F1

Operating manual

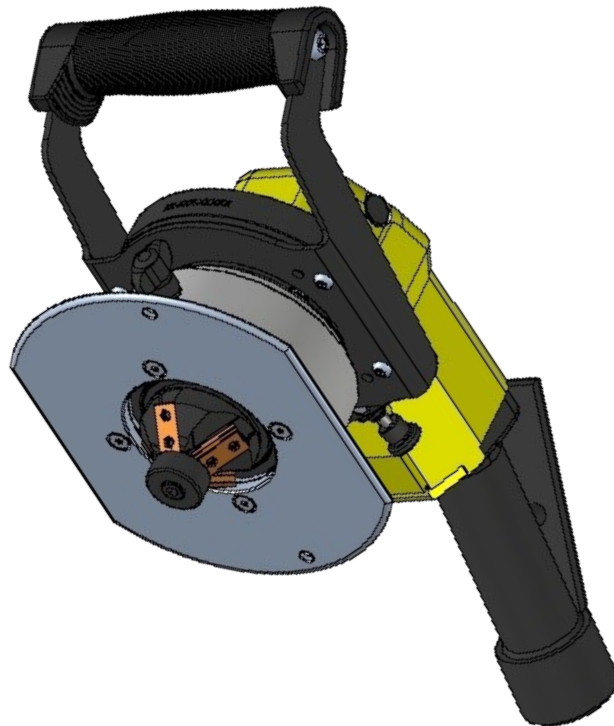

Operating manual SMA 60 BPV-46.F1

GERIMA GmbH  
Weimarer Straße 12  
D-66606 St. Wendel

Tel.: +49 (0) 6851 / 93951-0  
Fax.: +49 (0) 6851 / 93951-21  
E-Mail: [info@gerima.de](mailto:info@gerima.de)

All rights, including translation, are reserved. No part of this manual may be reproduced in any form (print, photocopy, microfilm or any other process) without the written permission of GERIMA GmbH, St. Wendel, reproduced or distributed using electronic systems, duplicated or distributed.

Subject to change.

<b>1</b>	<b>Preface.....</b>	<b>2</b>
1.1	Imprint.....	2
1.2	Foreword.....	4
1.3	Signs and symbols .....	5
<b>2</b>	<b>Technical specification.....</b>	<b>6</b>
2.1	Technical data.....	6
2.2	Shipment.....	6
2.3	Noise emission value.....	7
2.4	Power-on time.....	7
<b>3</b>	<b>Safety instructions.....</b>	<b>8</b>
3.1	Basic safety instructions.....	8
3.2	Intended use.....	14
<b>4</b>	<b>Settings.....</b>	<b>15</b>
4.1	Replacing guiding roll.....	15
4.2	Replacing carbide inserts.....	15
4.3	Replacing milling body.....	15
4.4	Setting the bevel length.....	15
4.5	Setting the radius.....	16
4.6	Consumables and accessories.....	17
<b>5</b>	<b>Operating mode.....</b>	<b>18</b>
5.1	Generally.....	18
5.2	Handling.....	18
<b>6</b>	<b>Maintenance.....</b>	<b>19</b>
<b>7</b>	<b>Disposal.....</b>	<b>19</b>
<b>8</b>	<b>Technical documentation.....</b>	<b>20</b>
<b>9</b>	<b>Terms of guarantee.....</b>	<b>23</b>
<b>10</b>	<b>EC Declaration of Conformity.....</b>	<b>24</b>

Dear customer,

Congratulations, you have purchased a highperformance beveling machine that will help you to achieve high-quality results in your beveling applications.

To ensure that the machine is used safely and effectively, please read this operating manual carefully in order to become properly acquainted with the machine.

Please instruct your co-workers and employees to become acquainted with the machine. Learning to use the machine properly will save you time and money, will save your employees time and effort, and will improve the quality of your products.

Due to our policy of continuous product improvement, the information contained in this manual may be subject to change without notice.

Please contact *GERIMA* for the latest product information.

To verify correct functioning, the machine underwent acceptance testing in which it processed sheet metal of a variety of thicknesses.

Should you need to contact us for assistance, please always have the identification number of your **GERIMA SMA 60 BPV-46.F1**.

The machine identification number is engraved on the gear box (see red arrow in diagram shown at top right of page).

<b>Machine identification number</b>

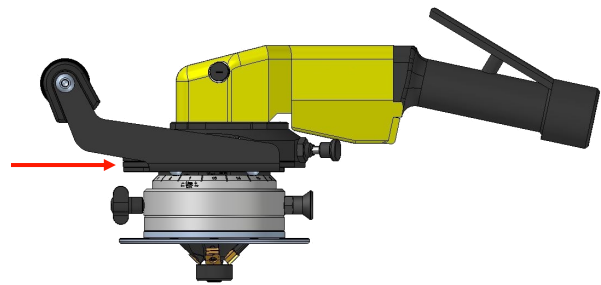

1. **Operating issues**  
If you have questions regarding the use or operation of the machine, or if you need our supportor advice regarding specialized applications, our team of specialist retailers and application technicians would be pleased to offer their assistance.
2. **Servicing and repair issues**  
If you need to make a guarantee claim, if the machine needs to be repaired or if you need to order spare parts, please contact our specialist retailers for help.
3. **Sales**  
Our specialist retailers are also the people to contact if you wish to purchase additional **GERIMA** machine.

To help us provide quick an efficient assistance, please always have your machine identification number to hand.

We hope you enjoy working with your precisionmade **GERIMA** machine.

The **GERIMA**-Team

**Please read the manual before using the machine !**

This manual has been created so that you can work with your device quickly and safely. Here is a brief guide on how you should read this manual:

- Read these operating instructions before working with the machine. Note especially the safety information.
- This manual is intended for people with basic technical knowledge in dealing with devices like the one described here. If you have no experience with such devices, you should first obtain the assistance of experienced person.
- Keep all documentation delivered with the device, so you can get information when needed. Keep your receipt for any warranty claims.
- If you lend or sell the machine once please give all equipment supplied documentation with.
- For damages which arises because these operating instructions were not followed, the manufacturer accepts no responsibility.

The information in this manual are identified as follows:



**Danger!**  
Warning of person, machinery or environmental damage.



**Entanglement!**  
Warning of personal damage by detection of body parts or clothing.



**Restart lock! Secure the machine against restarting and disconnect compressed air connection of the machine. Otherwise there is a danger of injury due to unintentional starting the power tool.**



**Stop!**  
Switch on the machine prohibited!



**Tip:**  
Additional information used to improve the knowledge.



**Ear protection!**  
Operating personnel must wear ear protection.



**Eye protection!**  
Operating personnel must wear eye protection.



**Hand protection!**  
The operator must wear protective gloves.



**Safety shoes!**  
The operator must wear safety shoes.



**Note that the substances / materials used to handle properly and must be disposed of according to regulations and laws.**

## Technical data

### Dimension and weight

Length  
Weight approx

### Connection value / power

Air connection  
Power  
Idle speed

### Noise emission

Sound power level Lwa / dB (A)

### Allowed materials and formats

Thickness of workpiece  
Bevel width

### Materials

Aluminium  
Steel  
Stainless steel

### Radius

## SMA 60 BPV-46.F1

410 mm  
approx. 8,5 Kg

6-7 bar, 40l/s  
2.100 W  
6.600 rpm

100 dB (A)

min. 3 mm  
1-30 mm  
(depending on material and guiding roll)

1-30 mm  
1-20 mm  
1-10 mm

2-15 mm  
(depending on material and guiding roll)

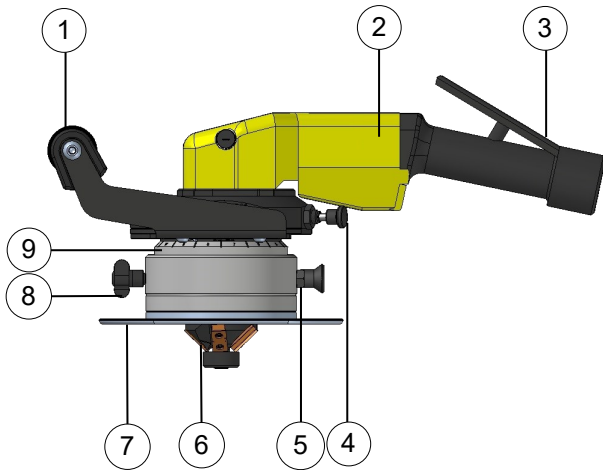

1. Handle
2. Motor
3. On-/Off-switch
4. Spindle lock
5. Bolt lock
6. Milling head with guiding roll
7. Guiding plate
8. Height clamping lever
9. Vernier scale

## Shipment

1x Basic machine SMA 60 BPV-46.F1  
(milling head not included)  
1x Manual  
1x Torx wrench T15  
1x Hexagon screwdriver SW5

**Noise emission values in accordance with the DIN EN 60745-1 standard:**

Noise emission	[dB (A)]	Value	Un-certainty
Emission sound pressure level	L <sub>pA</sub>	89	3
Peak emission sound pressure level at workplace (during milling operation)	L <sub>pGpeak</sub>	105	3
Sound power level	L <sub>WA</sub>	100	3

**Vibrations:**

Total vibration value (tri-axial vector sum)	Appropriate to DIN EN 60745:
<b>Work process:</b> - 30° milling head - <b>5 mm bevel width (C)</b> in 12 mm steel sheet S 355	Measured vibration emission value ah = 3,0 m/s <sup>2</sup>
	Uncertainty K = 1,5 m/s <sup>2</sup>
Total vibration value (tri-axial vector sum)	Appropriate to DIN EN 60745:
<b>Work process:</b> - 30° milling head - <b>8 mm bevel width (C)</b> in 12 mm steel sheet S 355	Measured vibration emission value ah = 6,0 m/s <sup>2</sup>
	Uncertainty K = 1,8 m/s <sup>2</sup>

**Note:**

The measured values listed above depend on the materials and operating procedures used and may therefore be exceeded under other operating conditions.

Using the machine to create bevels with a width greater than that permitted will result in a disproportionally large reduction in the machine's on-time and the service life of the indexable carbide inserts. The vibration and noise emission values will increase accordingly.

To prevent overloading the machine and to avoid operator fatigue it is very important to observe the maximum power-on periods especially when machining wide bevels or high-strength materials.

**Power-on time (POT):**

To avoid damaging the machine, it is essential to be monitor how long the machine has been operating continuously ('power-on time').

The compressed air that powers a pneumatic drive also serves to cool the motor as well. Pneumatic tools can therefore be operated for longer periods than electrically powered tools.

However, if the machine is subjected to particularly extreme loads (e.g. when machining wide bevels or very hard or tough materials) and/or if the machine is run for very long periods, the air cooling may still be insufficient to prevent overheating of the milling drive unit. If the operator continues to use the machine, the milling drive unit may overheat and be damaged as a result.

Material strength	C max.	POT max.
Aluminium, copper, brass	30mm	80%
Steel up to 400 N/mm <sup>2</sup>	20mm	60%
Steel up to 600 N/mm <sup>2</sup>	20mm	50%
Steel up to 900 N/mm <sup>2</sup>	20mm	40%
Stainless steel	10mm	40%

(C=bevel width, POT=power-on time)

**The power-on time is always expressed as a percentage of one hour.**

Example:

If the power-on time is specified as 50 %, then you can use the machine to mill bevels for a maximum of 30 min. in an hour and must then leave the machine to cool for 30 min.. If the machine is subjected to heavy loads, the power-on time might be 20 %, which means it can be used for 12 min. in any hour and must be left to cool for 48 min.. Before completely switching off the machine, we recommend running the machine for one or two minutes in idle mode (unloaded) so that fan can continue to draw cool air through the machine.

**Do not overload the machine!**

The machine can become overloaded if, for example, it continues to be used even though the bevel being cut is too large for the material being milled, or if the cutting inserts have become blunt and therefore unable to penetrate the material. Such conditions can lead to large machine vibrations or even machine breakdown.

To prevent this sort of damage when milling large bevels and/or hard materials, never try to machine the bevel in a single pass, always use multiple passes, and do not forget to change the carbide inserts before they become blunt or worn.

**Duties of the operator**

The SMA 60 BPV-46.F1 was designed and built taking into account a risk analysis and careful selection of the applicable harmonized standards and technical specifications. It thus corresponds to the prior art and allows for maximum safety during operation.

However, the machine safety can only be effectively implemented in practice, if all necessary measures have been taken. It is the duty of care and responsibility of the machine operator to plan these measures and to monitor their execution.

The operator must in particular ensure that:

- the machine must only be used for its intended use (see chapter intended use).
- the machine must only be operated in perfect working condition and especially the safety devices must be checked regularly for proper function.
- the required protective equipment for the operation, maintenance and repair staff must be available and must be used.
- the operating instructions must always in a good condition and fully available at the machine.
- only qualified and authorized staff may operate, maintain and repair the machine.
- this staff must be instructed regularly about relevant occupational safety and environmental protection and know the operating instructions and the safety instructions.
- all safety instructions and warnings attached to the machine must not be removed and must remain legible.



**The following instructions must be read carefully in order to avoid accidents to persons and / or property damage**

- Never attempt to operate the machine before you have read and understood the content of this operation manual.
- If you are unsure about any points, please contact *GERIMA* for assistance.
- Make sure that all persons who will be operating or servicing the machine have read and understood all the relevant safety information.
- Before starting the machine, the operator must ensure that all safety equipment is properly installed and functioning correctly.
- Never use the machine for purposes other than those specified in this manual. Never use the machine to process materials other than those approved for use by the machine's manufacturer. If you are considering using the machine for an unapproved purpose, please first contact *GERIMA* to request approval of your proposed application.
- Check that all air connections are secure and sound. Never attempt to service or repair the machine before it has been disconnected from the power supply.
- Always use genuine *GERIMA* spare parts and accessories or those that have been approved for use by *GERIMA*.

**If you encounter a problem or fault when operating the machine and you are unable to solve the issue with the aid of this manual, please contact *GERIMA* for rapid assistance.**



## Operator qualifications and protection of machine operators:

The term 'operator' is used here to mean any person who operates, adjusts, services and/or repairs the machine.

The employer is obliged to inform the operator about security relevant standards and to verify compliance.

To be trained operating personnel may initially work only under the supervision of an experienced person on the machine. Successful completion of training should be confirmed in writing.

All control and safety devices must always be operated only by trained personnel.

All persons carrying out work on the machine must read the operating instructions and confirm with their signature that they have understood the operating instructions.

The workplace must be well lit and provide sufficient space for safe working.



**Before working with or on the machine, the operator must have become acquainted with the machine and must have read and understood this manual.**

## The operator must

1. ensure that all guard plates are in place and all safety mechanisms are functioning correctly before starting the machine.



2. not wear clothing or accessories (jewellery etc.) that could be get trapped in moving machine parts.

3. always wear protective clothing (non-slip shoes, ear protection, gloves and safety goggles).
4. observe all relevant safety instructions. If a problem arises, the operator must refer to this manual before continuing with his or her work.

## Protective clothing:

When working on/with the machine always wear:



ear protectors,



safety goggles,



protective gloves,



safety shoes.

### Requirements to be met by operating staff:

The machine may only be operated by appropriately trained persons who have been instructed in the use of the machine and are authorized to operate it.

Operators must have read and understood this operating manual and must act in accordance with it. The functions of the operating personnel, i.e. what an operator is or is not allowed to do, must be clearly specified.

Special qualifications are required for the following activities:

- Commissioning: The machine may only be commissioned by the manufacturer.
- Operational training: Training in the use of the machine must be provided either by the manufacturer or by persons who have received appropriate instruction.
- Fault elimination: Faults may only be dealt with by appropriately qualified technical staff or by the manufacturer's service personnel.
- Maintenance: Maintenance work may only be performed by technical staff who have received appropriate instruction.
- Cleaning: The machine may only be cleaned by persons who have received appropriate instruction.
- Servicing: The machine may only be serviced by appropriately qualified technical staff or by the manufacturer's service personnel.
- Repair: The machine may only be repaired by appropriately qualified technical staff or by the manufacturer's service personnel.
- Decommissioning: Decommissioning of the machine may only be performed by appropriately qualified technical staff or by the manufacturer's service personnel.

### Risk of injury from hot metal chips:



- Hot chips are ejected from the machine at high speed.

### Improper use can cause serious injury:



- Make sure you always have a firm footing when working with the machine.
- Never touch the milling tool when the machine is running.
- Never use the machine above head height.
- Ensure the switch is in the off-position before connecting to power source. After use de-energize the machine by disconnecting it from the power supply!
- Only milling against the rotating direction = upcut milling

### Improper use can damage equipment and property:



- Risk of machine being damaged or destroyed.
- Never lift or carry the machine by its air hose.
- Make sure the air hose is directed behind and away from the machine. Do not lay the air hose over sharp edges.
- Always use genuine *GERIMA* spare parts and accessories.
- Check hose diameter and air pressure. The compressed air at the tool connection should have a max. operating pressure of 7 bar -700 kPa-100 psi - or lower, unless otherwise specified, when the machine is in operation.
- Avoid the risk of vibrating air hoses, regularly check the condition of the air hoses and the hose connections and clamps.



**Pneumatically-driven power tools are generally not insulated in a way that would allow them to come into contact with an electrical power source.**

- All work on the machine's air system must be performed only by qualified technicians.
- Pneumatically equipment must be checked regularly.
- Any loose connections must be reattached and any damaged air hoses replaced immediately.
- Avoid hazards associated with vibrating pneumatic tubing. Check the condition of the tubing, tube connectors and tube clamps regularly.
- The machine may only be operated with the prescribed air pressure strength.

### **Machine hazards :**

The machine has been built in accordance with the latest engineering standards and generally recognized safety principles. Nevertheless, improper use can result in serious or fatal injury to the user and/or third parties or cause damage to the machine or other property.

### **The machine must only be used:**

- For its intended purpose.
- If it is safe and in good repair.
- In compliance with the operating manual and by persons who are aware of the safety issues and hazards associated with the machine.
- Faults that could affect the safety of the machine must be remedied immediately.

### **Regular pre-start safety precautions**



Perform the following pre-start procedures each time you plan to use the machine:

- Check and ensure that all of the machine's safety and protective equipment is in place and functioning correctly.
- Check the machine for visible signs of damage. Any defects or deficiencies identified must be remedied immediately or reported to the supervisor. The machine may only be used if it is safe and in a state of good repair.
- Check and ensure that only authorized persons are within the machine's work area and that no other persons can be endangered by switching on the machine.
- All objects and other materials that are not needed for the operation of the machine must be removed from the machine's work area.
- The measures to be taken in an emergency are known.

### **Basic Safety Measures for Normal Operation:**



- The machine may only be started from the specified workstation.
- During operation of the machine safety devices must not be removed or rendered inoperable.
- The machine must be held with both hands!
- The operator may be present only at the specified workplace during operation of the machine.
- The operator must ensure that no unauthorized persons are in the working area of the machine.
- After switching off the machine, the operator must wait until all moving parts have stopped and the lights are off function.

### Maintenance:



**Maintenance or service work must only be performed once the machine's moving parts have come to rest. Machine parts may become very hot during operation.**



**Restart lock! Secure the machine against restarting and disconnect compressed air connection of the machine. Otherwise there is a danger of injury due to unintentional starting the power tool.**

### Machine hazard points:



#### **Milling head**

- Never touch the milling head when the machine is running.

### Safety information for servicing, maintenance and fault elimination:

- Any person who installs, commissions, operates, inspects, services or maintains the machine must have read and understood the operating manual and in particular the safety information contained therein.
- Machine adjustment, maintenance and inspection work must be carried by appropriately qualified technical staff.
- Servicing and maintenance work must only be carried out by appropriately qualified technical staff.
- All operating equipment must be secured against accidental activation or energization.
- When performing any servicing, maintenance or repair work de-energize the machine by disconnecting it from the supply and ensure that the machine cannot be switched on again accidentally. Put up a warning sign prohibiting reactivation of the machine (lock and tag out procedure).

- If protective guards or other safety devices have to be removed for servicing or maintenance work, they must be reinstalled immediately after the work has been completed.
- Use only listed operating and auxiliary materials.
- Use only genuine spare parts as listed in the spare parts list.
- Check bolted connections for tightness.
- Before restarting the machine, make sure that nobody can be endangered by the running machine.
- Any unsafe operation is prohibited!
- Never put safety devices inoperative!
- Never wear hanging or protruding clothes which could become trapped in moving machine parts!
- After maintenance check all safety devices for function!

### Consequences when nonobservance:



- Injury hazards for personnel!
- Damage to the machine!
- Modifications of the machine can affect the correct operation and safety of the machine!

**Modifications to the machine:**



The machine may not be modified, added to or converted unless the prior consent of the manufacturer has been granted.

Any alterations to the machine must have been approved by GERIMA GmbH. This also applies to the welding of the component parts.

**Cleaning the machine and disposal information:**



All substances and materials used must be handled appropriately and accordance with all relevant statutory provisions and legislation.

The machine must only be cleaned after it has been switched off!

**Machine noise:**

The continuous sound power level emitted by the machine at the installation site is greater than > 84 dB (A).



Operating personnel must wear ear protection!

**Residual risks:**

- The machine was plant and constructed with all suitable devices to guarantee the safety and health of the operator.
- The machine is covered to prevent the risk of contact with moving parts.
- However residual risks still exist.
- As already mentioned the cutting area is protected as far as possible but there is an opening portion through which the processing material must be introduced.
- It is possible that the operator reaches in this area with his hands.



**Always keep your hands as far as possible away from the cutting area!**



**Always observe the safety rules to minimize the residual risks!**



**Be aware that the machine may be a source of residual mechanical or pneumatically energy. Appropriate precautions for dealing with these hazardous energy sources must be taken when instructing operating personnel on the use of the machine.**

**The hand-held beveling machine SMA 60 BPV-46.F1 may only be used for work and materials described in the section 'intended use'.**



**Do not use the machine to work on materials containing asbestos!**

The SMA 60 BPV-46.F1 is a hand-held, pneumatically powered beveling machine intended:

- For machining workpieces made of steel, cast steel, fine-grained steel, stainless steel, aluminium, aluminium alloy, brass and plastic.
- For commercial use in industrial settings and in the skilled-trades.
- For preparing K-, V-, X-, and Y-shaped welding grooves.
- For creating visible edges in plant and mechanical engineering work.
- For rounding off of edges for an optimal painting preparation or as a scratch and bump protection.

## Replacing guidind roll / carbide inserts / milling body



Before replacing the machine must be disconnected from the compressed air supply and secured against reconnection.

- A** Lock the spindle, then loosen the guiding roll with the hexagonal wrench SW 5 and lift/ remove the guiding roll.

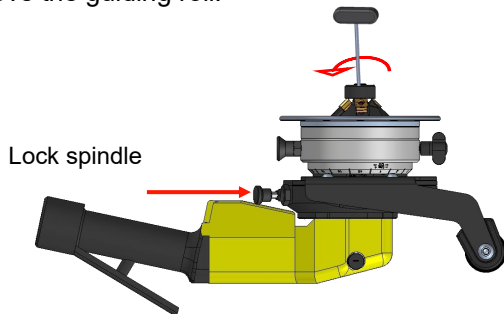

- B** Loosen the clamping screws with the Torx wrench T15 and replace the carbide inserts. The inserts must be fastened to the mounting seat on the milling head by means of the original locking screws (max. tightening torque: 4.0-5.0 Nm).



**Attention: Wear gloves due to risk of cutting and burns**

- C** Loosen the milling head retaining screw with the hexagonal wrench SW 5 and remove the milling head.

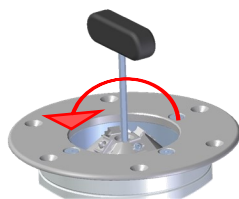

To remove the milling head easier out of the guiding of the driving shaft you have to turn the guiding roll a little bit into the milling head and use the guide wheel as a handle to lift the milling head up.



**Please note:**  
At tighten of the holding screw of the milling head always turn to the stop so that the locking washer is active in the milling head.

## Setting the bevel length

- a leg length = bevel length a
- b leg length = bevel length b
- C bevel width
- $\alpha$  bevel angle
- $\beta$  opposite angle
- A bevel size
- h bevel height
- S oddment
- t plate thickness

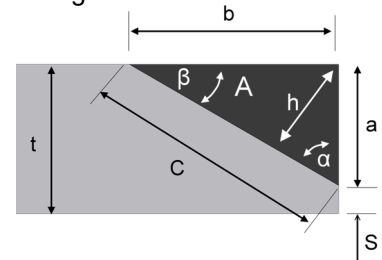

The bevel length (a) is set by adjusting the position of the guide plate (2). The height setting can be read out at the main scale (1) and the vernier collar (4). Release locking pin (5) and clamping screw (3). Rotate the guide plate (2) until the required bevel length has been set as shown by the main scale (1) in combination with the vernier scale on the collar (4). Retighten clamping screw (3) and lock locking pin (5).

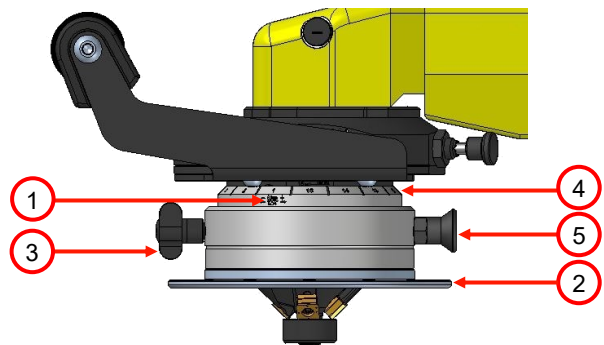

Once the bevel height has been set, a bevel should be milled on a test sample to check whether further height adjustments are required. These may be necessary because the precision of the scale is approximately  $\pm 1$  mm, depending on the type of milling head fitted.

The values below are experical values, no guarantee values! Some materials can harden on the edges of the workpiece when working with flame cutting, plasma and laser cutting. This can result in significant deviations from the specified reference values.

### Adjusting the radii:

Please note that only the position of the upper edge of the radius can be adjusted by rotating the guiding plate. The lateral position of the radius on the workpiece end face is determined by the guide wheel fitted and cannot be altered.

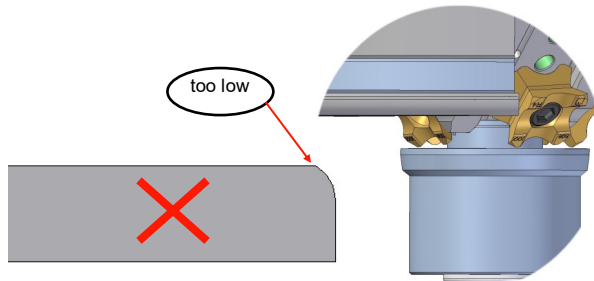

Guiding plate set too low (radius incomplete)

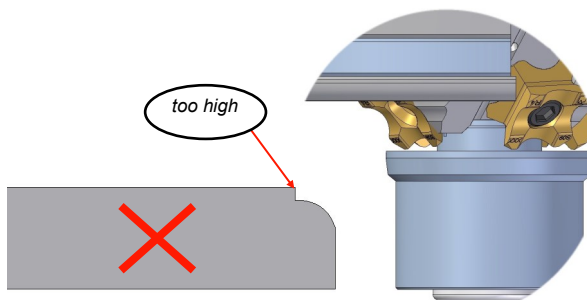

Guiding plate set too high (radius cuts into material)

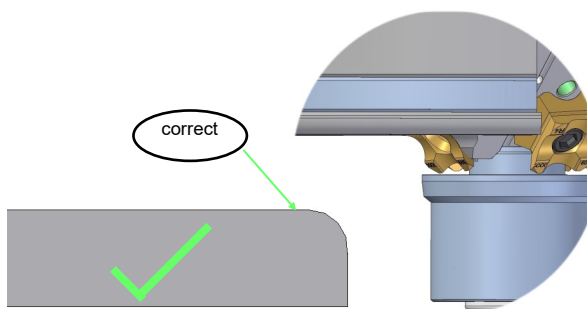

Guiding plate set correctly (radius fully formed with smooth transition to workpiece surfaces)

### Notes on radius milling:

Choosing the right guiding roll ensure the correct lateral position of the radius is just as important as setting the correct height of the guiding plate. If the wrong guiding roll is used, the machined radius will not form a smooth transition with the end face of the workpiece.

If the guiding roll used is too large, the appearance of the resulting radius is similar (but rotated by 90°) to that created when the guiding plate is set too low.



Guiding roll too large (radius incomplete)

If the guiding roll used is too small, the appearance of the resulting radius is similar (but rotated by 90°) to that created when the guiding plate is set too high.

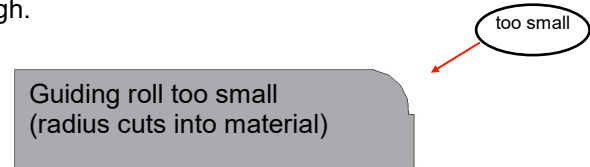

Guiding roll too small (radius cuts into material)

The same phenomenon arises if the end and upper faces of the workpiece are not aligned at right angles to one another.

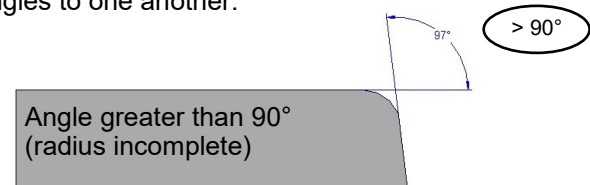

Angle greater than 90° (radius incomplete)

If the edge of workpiece to be machined was created by cutting with a plasma cutter, the upper and end faces of the workpiece may be out of rectangular alignment by as much as 7°. This type of misalignment will result in a radius that is either incomplete or that cuts too far into the material depending on whether the upper or lower surface of the workpiece is being machined.

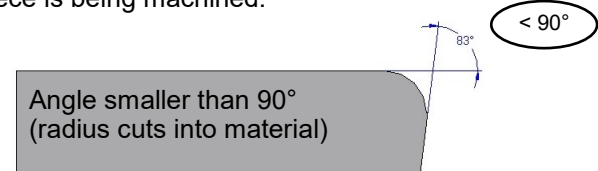

Angle smaller than 90° (radius cuts into material)

Although our conically shaped guiding rolls are designed to put up against the workpiece immediately below the carbide inserts and can therefore minimize the problem, they cannot eradicate it entirely. Machining a correct radius therefore requires a 90° angle between the adjacent faces of the workpiece.

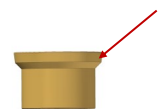



## Overview and order numbers carbide inserts for bevel and radii:

Function	Name of part	Aluminium Copper Brass	Steel up to 600 N/ mm <sup>2</sup>	Steel up to 900 N/ mm <sup>2</sup>	Stainless steel	Order-nr.
Bevel	DX4.B10-V1	x				0101.404.19-00078
	DX4.B12-V1		x		x	0101.404.19-00079
	DX4.B15-V1			x		0101.404.19-00080
Radius 3mm	R3-KX8.B20-V1	x				0101.404.19-00023
	R3-KX8.B22-V1		x		x	0101.404.19-00024
	R3-KX8.B25-V1			x		0101.404.19-00035
Radius 4mm	R4-KX8.B20-V1	x				0101.404.19-00025
	R4-KX8.B22-V1		x		x	0101.404.19-00026
	R4-KX8.B25-V1			x		0101.404.19-00036
Radius 5mm	R5e-KX8.B20-V1	x				0101.404.19-00027
	R5e-KX8.B22-V1		x		x	0101.404.19-00028
	R5e-KX8.B25-V1			x		0101.404.19-00033
Radius 6mm	R6e-KX8.B20-V1	x				0101.404.19-00029
	R6e-KX8.B22-V1		x		x	0101.404.19-00030
	R6e-KX8.B25-V1			x		0101.404.19-00032
Radius 8mm	R8-FV4.B10-V1	x				0101.404.19-00039
	R8-FV4.B12-V1		x		x	0101.404.19-00040
	R8-FV4.B15-V1			x		0101.404.19-00041
Radius 10mm	R10-NV2.B10-V1	x				0101.404.19-00042
	R10-NV2.B12-V1		x		x	0101.404.19-00043
	R10-NV2.B15-V1			x		0101.404.19-00044
Radius 12mm	R12-NV2.B10-V1	x				0101.404.19-00045
	R12-NV2.B12-V1		x		x	0101.404.19-00046
	R12-NV2.B15-V1			x		0101.404.19-00047
Radius 15mm	R15-NV2.B10-V1	x				0101.404.19-00048
	R15-NV2.B12-V1		x		x	0101.404.19-00049
	R15-NV2.B15-V1			x		0101.404.19-00050



General note: For radius > 8mm, work 45° bevel before

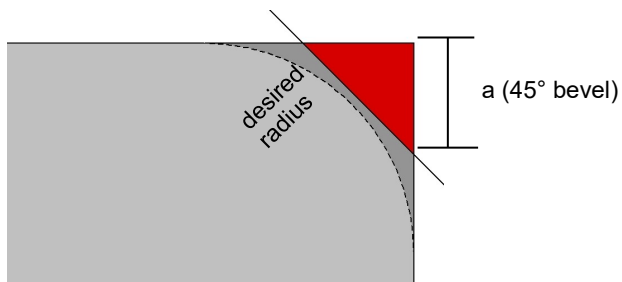

radius [mm]	a [mm]
10	5
12	6,5
15	8

## General:



### Two-handed operation:

Whatever the position of the machine, always use two hands to control the machine.

When working with the machine, make sure that the machine is always held with two hands (see red arrows) and in such a way that both hands are kept away from the machining point.

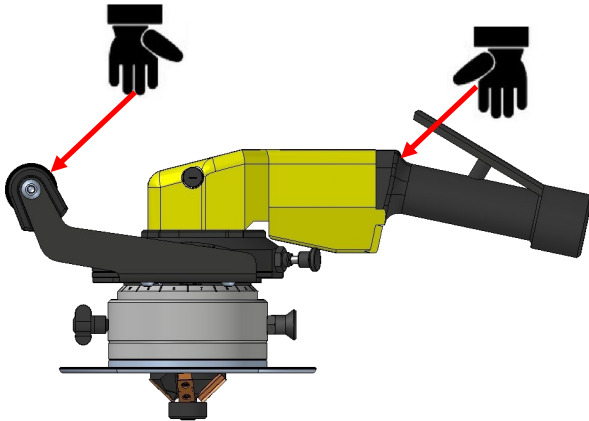

### Ensure that the workpiece is securely clamped!



- for safety reasons
- to improve the service life of the carbide inserts
- to prevent damage to the milling machine

### Important!

Before machining a workpiece, make sure that it is securely clamped so that it cannot slip.

This should be done to ensure safe working so that the workpiece does not slip or even fly off when being milled and to prevent unnecessary vibrations in the workpiece material.

The less vibration generated in the workpiece, the longer the service life of the carbide inserts.



**To become acquainted with the machine, you must start by machining a small bevel with a width of no more than 2 mm and remember to advance the machine slowly first. Bevels of maximum width can only be machined safely and reliably once you have become used to handling the machine.**

## Handling:



### Damages caused by wrong power supply!

- Check values air connection. The air pressure must correspond with the specifications on the type plate of the machine.



### Improper use can cause serious injury!

- Make sure you always have a firm footing when working with the machine!
- Never touch the milling head when the machine is running!
- Always lead the machine away from body during working, never use the machine above head height.



### Risk of damage to equipment and property!

- Working with worn or damaged carbide inserts or milling heads will cause the machine to fail!
- Avoid collisions when working with the machine!

## Working with the machine:

Press on-/off-switch (1).

**Motor starts.** Bring the machine slowly into contact with the workpiece only after the selected tool speed has been reached.

### Machining the workpiece (up-cut milling)

When milling a bevel always move the machine from left to right against the direction of rotation of the milling head (up-cut milling).

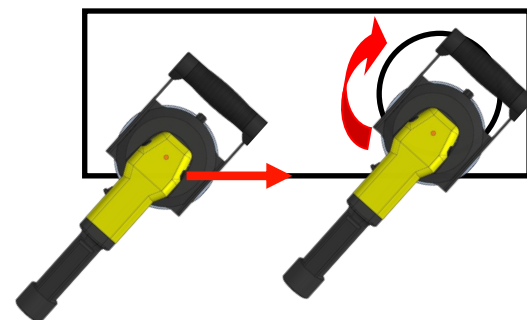

### Switching off the machine

- remove the machine from the workpiece.
- release the on-/off-switch.
- once the motor is switched off, wait for it to come to a standstill before placing the machine down on a surface.

## Maintenance



Before servicing the machine always must be disconnected from the compressed air supply and secured against reconnection.



Repair must only be carried out by a GERIMA trained technician!



**Improperly repaired machines are hazzard!**

- Increased risk of injury
- Machine does not function correctly!



**Hot carbide inserts and milling head!**

- Burn hazzard!
- Wear protective gloves when replacing the carbide inserts!

## Blunt tool can cause damage!



- Blunt tool can overload the machine!
- Inspect milling tools regularly for signs of wear.
- Wear protective gloves when changing or readjusting the carbide inserts!

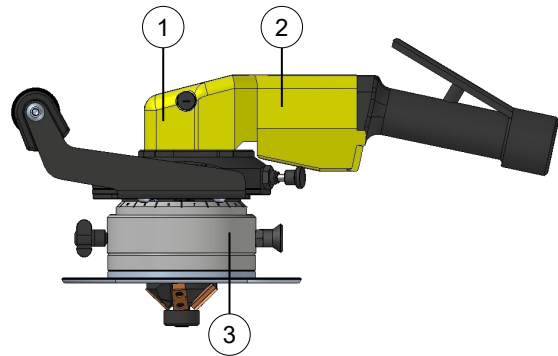

## Maintenance plan:

Part to be serviced	Type of maintenance work	Service	Maintenance procedure	Materials required	Order-nr.
Gear box ①	re-grease approx. every 1000 operating hours	certified <b>GERIMA</b> service agent	disassemble gear box	lubrication greaset	0109.007.10-00002
Motor laminations ②	replace as necessary	certified <b>GERIMA</b> service agent	stave replace	stave-set	0109.113.09-00029
Height adjuster thread ③	clean and lubricate as necessary	trained technician	disassemble guide plate unit	teflon pray	0109.007.10-00005
Carbide inserts	rotate or replace as necessary	machine operator	see page 15	torx-key T15	see page 17

### Service 1:

Open screw (arrow) and max. top up with 17 ml of lubricant. The normal consumption is approx. 10 ml / 1,000 operating hours. Approx. 0.25 ml are filled up per actuation of the grease gun.

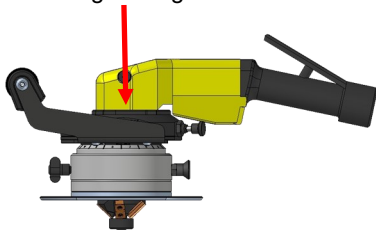

### Service 2:

A slat replacement should only be certified by one. GERIMA service or Atlas Copco service are carried out, otherwise the guarantee claims will be lost.

### Service 3:

Unscrew the guide plate, unscrew the guide plate holder, clean the thread, spray with teflon spray and reinstall.



## Disposal of components removed from the machine

All machine parts and operating and auxiliary materials must be disposed of in accordance with the applicable statutory provisions.

Gear box unit SMA 60 BPV-46.F1

0202-05-01-03-00-00

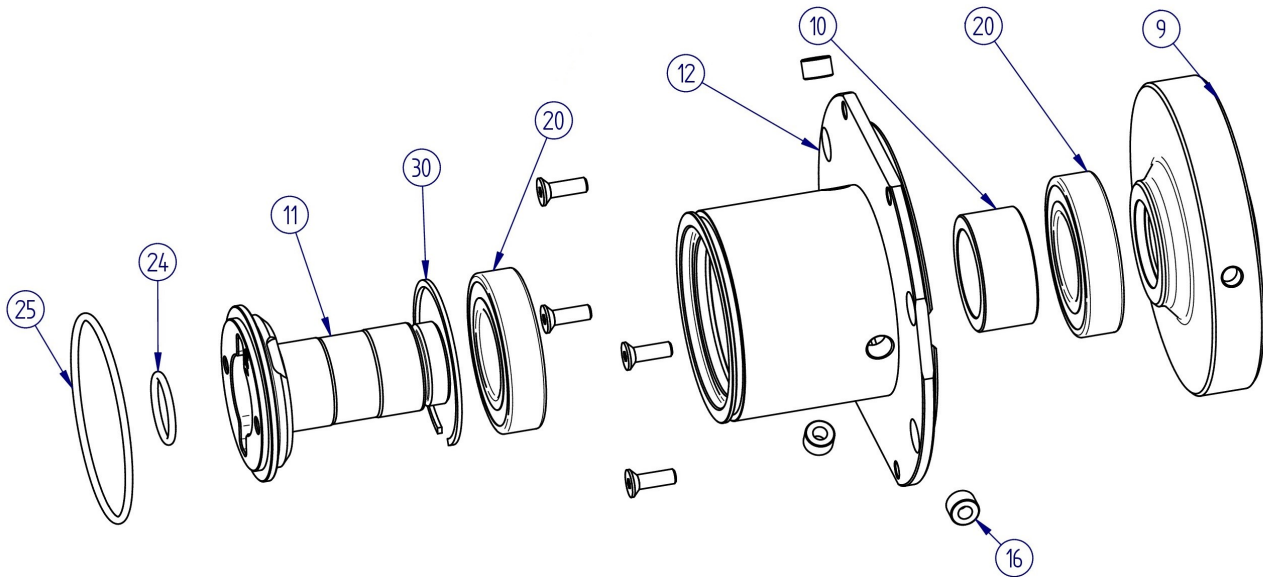

nr.	name of part	order-nr.	pc.
9	Flywheel	0109.252.19-00004	1
10	Spacer sleeve	0109.122.20-00002	1
11	Drive shaft, divided below	0109.122.20-00003	1
12	Bearing housing (lower part)	0109.122.20-00004	1
16	Thread insert M6x14	0101.143.09-00023	3
20	Deep groove ball bearing	0000.012.14-00035	2
24	O-ring	0000.042.14-00013	1
25	O-ring	0000.042.14-00009	1
30	Snap ring	0000.022.14-00202	1

Gear box unit SMA 60 BPV-46.F1

0202-05-01-03-00-00

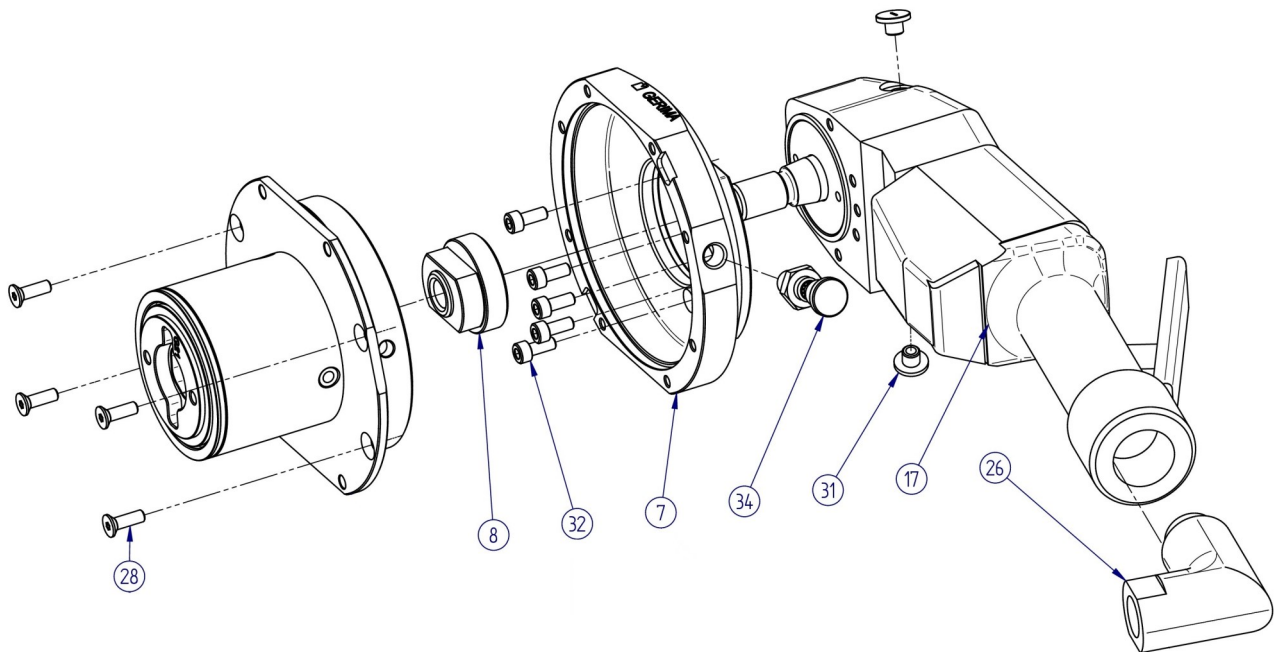

nr.	name of part	order-nr.	pc.
7	Bearing housing (upper part)	0109.252.19-00007	1
8	Drive shaft driver	0109.252.19-00006	1
17	Drive unit (6.600 rpm)	0109.103.09-00033	1
26	Swivel connection 1/2 inch	0109.007.09-00001	1
28	Countersunk screw M5x16	0000.022.14-00116	4
31	Closing plug	0000.032.16-00058	2
32	Cylinder screw M5x12	0000.022.15-00191	5
34	Spring bolt	0000.032.18-00121	1

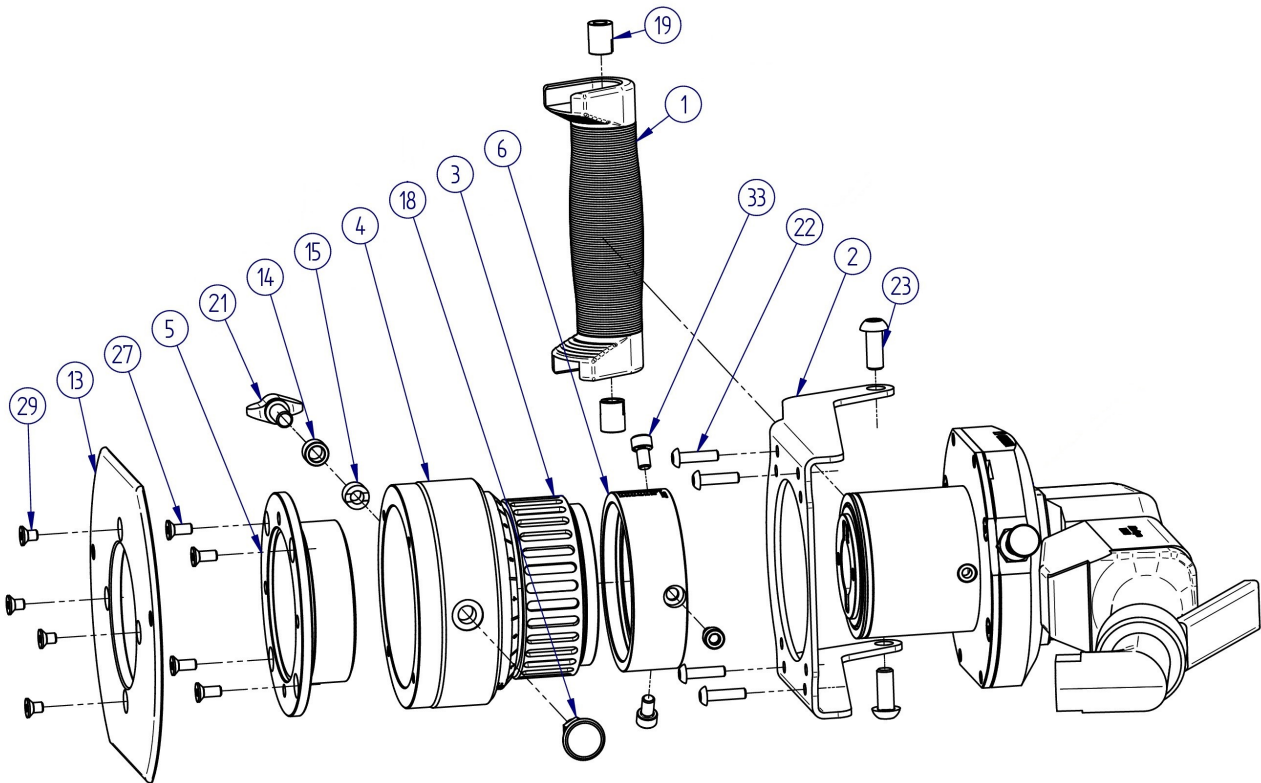

nr.	name of part	order-nr.	pc.
1	Round handle	0101.482.19-00025	1
2	Holding plate handle	0101.442.18-00021	1
3	Steel sleeve with grooves	0101.452.20-00009	1
4	Lock ring	0101.452.20-00008	1
5	Holder guiding plate	0101.452.20-00007	1
6	Guide plate adapter	0101.452.20-00006	1
13	Guiding plate	0109.123.09-00002	1
14	Spacer ring	0101.143.09-00032	1
15	Thread insert M8x15	0101.143.09-00033	1
18	Locking bolt with locking groove	0000.032.16-00124	1
19	Thread insert M8x15	0000.022.14-00117	2
21	Wing screw M8x20	0000.032.14-00058	1
22	Hexagon socket screw M5x20	0000.022.15-00221	4
23	Hexagon socket screw M8x20	0000.022.14-00205	2
27	Countersunk screw M5x12	0000.022.14-00108	4
29	Countersunk screw M5x8	0000.022.14-00115	4
33	Cylinder screw M6x10	0000.022.14-00118	3

*GERIMA* shall guarantee a new machine for a period of twelve months beginning on the date the machine was purchased from the *GERIMA* production facility in 66606 St. Wendel, Germany.

Any further guarantees shall require the prior written agreement of both the machine owner and the manufacturer.

The guarantee provides that the machine is free from defects in materials and/or workmanship. Any performance data contained in information or promotional materials or included in quotations are understood to be for guidance only and are not guaranteed, as these values depend very strongly on the material worked and the particular machining operation used.

Any guarantee claim submitted must state the machine identification number and must be accompanied by the relevant delivery note or invoice.

Repairs under guarantee may only be carried out by *GERIMA* or by one of its authorized specialist retailer or representatives.

Guarantee claims can be made only for genuine *GERIMA* parts and if the machine was used for its intended purpose. The guarantee does not cover, in particular: operational wear and tear; improper use; partially or wholly disassembled machines; damage arising from overloading the machine or from the incorrect use of the milling tool; the use of non genuine, unauthorized or defective parts; damage caused by the machine to the workpiece; use of excessive force; consequential damage arising from improper or inadequate maintenance by the customer or a third party; damage caused by unauthorized third parties or by the presence of foreign matter; damage arising from a failure to comply with the manufacturer's operating instructions, e.g. connecting the machine to the wrong power supply.

Services provided under the guarantee are understood to be 'ex works' (66606 St. Wendel, Germany).

Any additional costs, such as travel costs for technical personnel, shipping costs etc. are not covered by the guarantee and will be charged.

After receiving a defective machine, *GERIMA* shall compile a cost estimate of the repairs and shall provide notification of the extent to which these repairs are covered by the guarantee.

Once accepted, the machine will be repaired and then either dispatched with invoice or stored ready for collection.

## Declaration of Conformity in accordance with the EC Machinery Directive, Annex II, 1A

Translation - EC Declaration of Conformity

Manufacturer

GERIMA GmbH  
Phone no: (0049) 6851-93951-70  
Fax: (0049) 6851-93951-21  
E-Mail: info@gerima.de  
Internet: www.gerima.de  
Weimarer Straße 12  
66606 St. Wendel  
Germany

Authorized representative according to MRL

GERIMA GmbH  
Phone no: (0049) 6851-93951-70  
Fax: (0049) 6851-93951-21  
E-Mail: info@gerima.de  
Internet: www.gerima.de  
Weimarer Straße 12  
66606 St. Wendel  
Germany

Authorized representative technical documents

Dipl.-Ing. Stephan Rieth  
GERIMA GmbH  
Phone no: (0049) 6851-93951-70  
Fax: (0049) 6851-93951-21  
E-Mail: info@gerima.de  
Internet: www.gerima.de  
Weimarer Straße 12  
66606 St. Wendel  
Germany

Product

SMA 60 BPV-46.F1, 21-315-\*\*\*\*\*, 00001-99999, 2021

We hereby declare that the above mentioned product complies with all relevant provisions of the Machinery Directive 2006/42/EC.  
The above product fulfills the relevant requirements of the following guidelines:

- ▶ Directive 2006/42/EC of the European Parliament and the Council of 17 May 2006 on machinery and amending Directive 95/16/EC (recast) 2006/42/EC

and corresponds to the following standards:

- ⇒ **DIN EN 60745-1/A11 VDE 0740-1/A11:2011-09**  
**Hand-held motor-operated electric tools - Safety**  
Part 1: Generell requirements  
German Version EN 60745-1:2009/A11:2010

St. Wendel, 01.01.2021



Dipl.-Ing. Stephan Rieth, Business Management