

Hand-held beveling machine

SMA 20 AEF-24.K1

SMA 20 AEF-14.K1

Operating manual

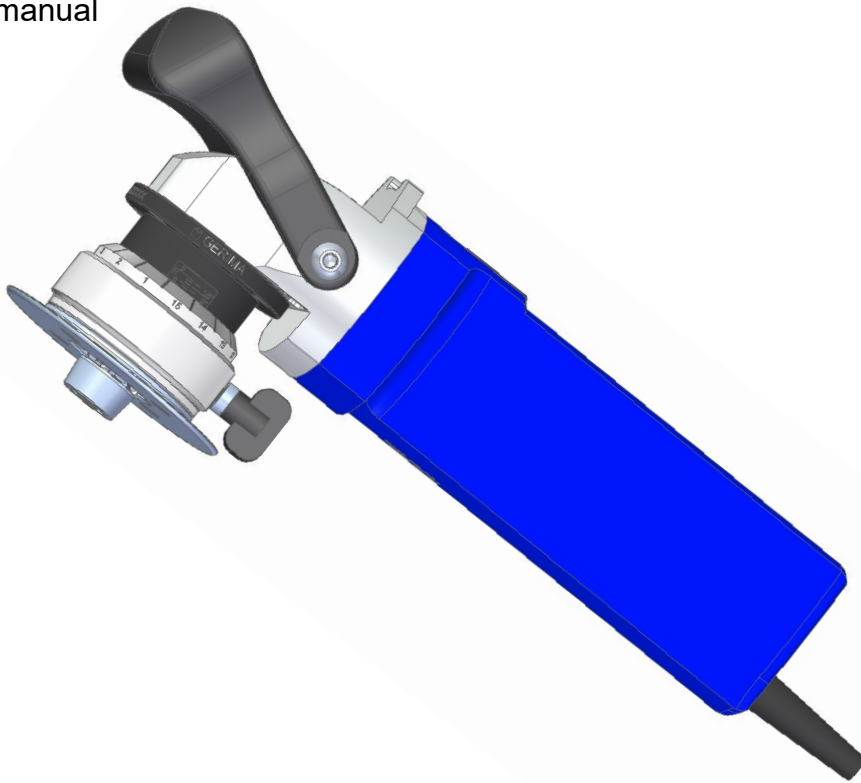

Operating manual SMA 20 AEF-24.K1 / SMA 20AEF-14.K1

GERIMA GmbH
Weimarer Straße 12
D-66606 St. Wendel

Tel.: +49 (0) 6851 / 93951-0
Fax.: +49 (0) 6851 / 93951-21
E-Mail: info@gerima.de

All rights, including translation, are reserved. No part of this manual may be reproduced in any form (print, photocopy, microfilm or any other process) without the written permission of GERIMA GmbH, St. Wendel, reproduced or distributed using electronic systems, duplicated or distributed.

Subject to change.

| | | |
|-----------|--|-----------|
| 1 | Preface..... | 2 |
| 1.1 | Imprint..... | 2 |
| 1.2 | Foreword..... | 4 |
| 1.3 | Signs and symbols | 5 |
| 2 | Technical specification..... | 6 |
| 2.1 | Technical data..... | 6 |
| 2.2 | Shipment..... | 6 |
| 2.3 | Noise emission value..... | 7 |
| 2.4 | Power-on time..... | 7 |
| 3 | Safety instructions..... | 8 |
| 3.1 | Basic safety instructions..... | 8 |
| 3.2 | Intended use..... | 13 |
| 4 | Settings..... | 14 |
| 4.1 | Replacing guiding roll..... | 14 |
| 4.2 | Replacing carbide inserts..... | 14 |
| 4.3 | Setting the bevel length..... | 15 |
| 4.4 | Setting the radius..... | 15 |
| 4.5 | Consumables and accessories..... | 15 |
| 5 | Operating mode..... | 16 |
| 5.1 | Generally..... | 16 |
| 5.2 | Handling..... | 16 |
| 6 | Maintenance..... | 17 |
| 7 | Disposal..... | 17 |
| 8 | Technical documentation..... | 18 |
| 9 | Terms of guarantee..... | 19 |
| 10 | EC Declaration of Conformity..... | 20 |

Dear customer,

Congratulations, you have purchased a highperformance beveling machine that will help you to achieve high-quality results in your beveling applications.

To ensure that the machine is used safely and effectively, please read this operating manual carefully in order to become properly acquainted with the machine.

Please instruct your co-workers and employees to become acquainted with the machine. Learning to use the machine properly will save you time and money, will save your employees time and effort, and will improve the quality of your products.

Due to our policy of continuous product improvement, the information contained in this manual may be subject to change without notice.

Please contact *GERIMA* for the latest product information.

To verify correct functioning, the machine underwent acceptance testing in which it processed sheet metal of a variety of thicknesses.

Should you need to contact us for assistance, please always have the identification number of your **GERIMA SMA 20 AEF-24.K1 / SMA 20 AEF-14.K1** available.

The machine identification number is engraved on the gear box (see red arrow in diagram shown at top right of page).

| |
|-------------------------------|
| Machine identification number |
| |

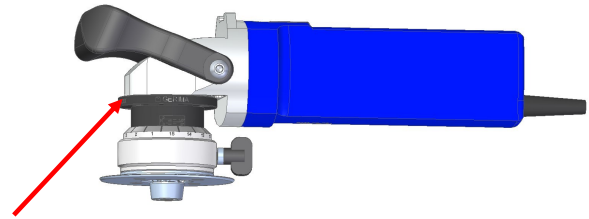

1. **Operating issues**

If you have questions regarding the use or operation of the machine, or if you need our support or advice regarding specialized applications, our team of specialist retailers and application technicians would be pleased to offer their assistance.

2. **Servicing and repair issues**

If you need to make a guarantee claim, if the machine needs to be repaired or if you need to order spare parts, please contact our specialist retailers for help.

3. **Sales**

Our specialist retailers are also the people to contact if you wish to purchase additional **GERIMA** machine.

To help us provide quick and efficient assistance, please always have your machine identification number to hand.

We hope you enjoy working with your precisionmade **GERIMA** machine.

The **GERIMA**-Team

Please read the manual before using the machine !

This manual has been created so that you can work with your device quickly and safely. Here is a brief guide on how you should read this manual:

- Read these operating instructions before working with the machine. Note especially the safety information.
- This manual is intended for people with basic technical knowledge in dealing with devices like the one described here. If you have no experience with such devices, you should first obtain the assistance of experienced person.
- Keep all documentation delivered with the device, so you can get information when needed. Keep your receipt for any warranty claims.
- If you lend or sell the machine once please give all equipment supplied documentation with.
- For damages which arises because these operating instructions were not followed, the manufacturer accepts no responsibility.

The information in this manual are indentified as follows:



Danger!
Warning of person, machinery or environmental damage.



Risk of electric shock!
Warning of damage caused by electricity.



Entanglement!
Warning of personal damage by detection of body parts or clothing.

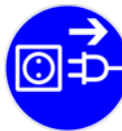

Before this step, unplug the mains plug from the power socket.
Otherwise there is a danger of injury due to unintentional starting the power tool.



Tip:
Additional information used to improve the knowledge.



Ear protection!
Operating personnel must wear ear protection.



Eye protection!
Operating personnel must wear eye protection.



Hand protection!
The operator must wear protective gloves.



Safety shoes!
The operator must wear safety shoes.



Note that the substances / materials used to handle properly and must be disposed of according to regulations and laws.

Technical data

Dimension and weight

Length
Weight approx

Connection value / power

Line voltage
Power
Idle speed

Noise emission

Sound power level Lwa / dB (A)

Allowed materials and formats

Thickness of workpiece
Bevel width
Radius

Materials

Steel
Stainless steel
Aluminium

SMA 20 AEF-24.K1

353 mm
2,95 Kg

230 V / 50/60 Hz
1.200 W
11.000 rpm

100 dB (A)

min. 3 mm
1-7 mm
1,2-2,5 mm
(depending on material)

1-5 mm
1-3 mm
1-5 mm

SMA 20 AEF-14.K1

353 mm
2,95 Kg

110/120 V / 50/60 Hz
1.100 W
11.000 rpm

100 dB (A)

min. 3 mm
1-7 mm

1-5 mm
1-3 mm
1-5 mm

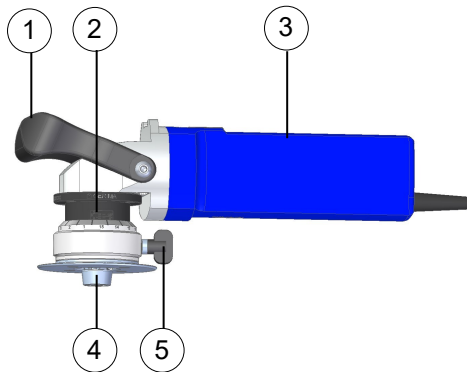

1. Handle
2. Main scale
3. Motor
4. Milling head with guiding roll
5. Height clamping lever

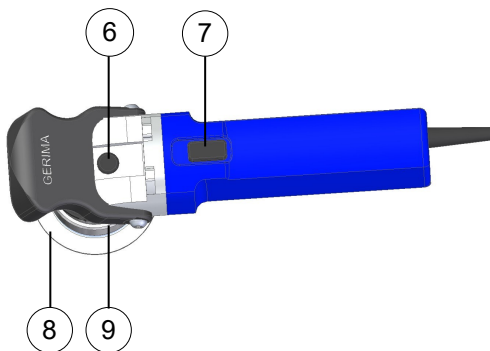

6. Spindle lock
7. On-/Off-switch
8. Guiding plate
9. Vernier scale

Shipment

1x Basic machine SMA 20 AEF-24.K1 **or**
SMA 20 AEF-14.K1 with milling head
1x Manual
1x Torx wrench T15
1x Screwdriver SW4

Noise emission values in accordance with the DIN EN 60745-1 standard:

| Noise emission | [dB (A)] | Value | Un-certainty |
|--|---------------------|-------|--------------|
| Emission sound pressure level | L _{pA} | 89 | 3 |
| Peak emission sound pressure level at workplace (during milling operation) | L _{pGpeak} | 104 | 3 |
| Sound power level | L _{WA} | 100 | 3 |

Vibrations:

| Total vibration value (tri-axial vector sum) | Appropriate to DIN EN 60745: |
|--|--|
| Work process: - 45° milling head - 5 mm bevel width (C) in 12 mm steel sheet S 355 | Measured vibration emission value ah = 3,0 m/s ² |
| | Uncertainty K = 1,5 m/s ² |

Note:

The measured values listed above depend on the materials and operating procedures used and may therefore be exceeded under other operating conditions.

Using the machine to create bevels with a width greater than that permitted will result in a disproportionally large reduction in the machine's on-time and the service life of the indexable carbide inserts. The vibration and noise emission values will increase accordingly.

To prevent overloading the machine and to avoid operator fatigue it is very important to observe the maximum power-on periods especially when machining wide bevels or high-strength materials.

Power-on time (POT):

To avoid damaging the machine, it is essential to be monitor how long the machine has been operating continuously ('power-on time').

All electric brushed motors generate large amounts of heat in the rotor and stator. Although the machine is fitted with a fan cooler that dissipates the heat produced, if the machine is subjected to extreme loads (e.g. milling large bevels, very hard or tough materials) and/or is run continuously for a long period of time, the cooling system may not be able to cope with the amount of heat generated. If the operator continues to use the machine, the rotor (armature) may overheat to such an extent that the winding insulation melts causing a short circuit.

| Material strength | C max. | POT max. |
|-----------------------------------|--------|----------|
| Aluminium, copper, brass | 5mm | 80% |
| Steel up to 400 N/mm ² | 5mm | 50% |
| Steel up to 600 N/mm ² | 4mm | 40% |
| Steel up to 900 N/mm ² | 3mm | 30% |
| Stainless steel | 3mm | 20% |

(C=bevel width, POT=power-on time)

The power-on time is always expressed as a percentage of one hour.

Example:

If the power-on time is specified as 50 %, then you can use the machine to mill bevels for a maximum of 30 min. in an hour and must then leave the machine to cool for 30 min.. If the machine is subjected to heavy loads, the power-on time might be 20 %, which means it can be used for 12 min. in any hour and must be left to cool for 48 min.. Before completely switching off the machine, we recommend running the machine for one or two minutes in idle mode (unloaded) so that fan can continue to draw cool air through the machine.

Do not overload the machine!

The machine can become overloaded if, for example, it continues to be used even though the bevel being cut is too large for the material being milled, or if the cutting inserts have become blunt and therefore unable to penetrate the material. Such conditions can lead to large machine vibrations or even machine breakdown if the armature in the motor is bent to such an extent that the rotor and stator rub against each other, overloading the windings and blowing the motor.

To prevent this sort of damage when milling large bevels and/or hard materials, never try to machine the bevel in a single pass, always use multiple passes, and do not forget to change the carbide inserts before they become blunt or worn.

Duties of the operator

The SMA 20-AEF was designed and built taking into account a risk analysis and careful selection of the applicable harmonized standards and technical specifications. It thus corresponds to the prior art and allows for maximum safety during operation.

However, the machine safety can only be effectively implemented in practice, if all necessary measures have been taken. It is the duty of care and responsibility of the machine operator to plan these measures and to monitor their execution.

The operator must in particular ensure that:

- the machine must only be used for its intended use (see chapter intended use).
- the machine must only be operated in perfect working condition and especially the safety devices must be checked regularly for proper function.
- the required protective equipment for the operation, maintenance and repair staff must be available and must be used.
- the operating instructions must always in a good condition and fully available at the machine.
- only qualified and authorized staff may operate, maintain and repair the machine.
- this staff must be instructed regularly about relevant occupational safety and environmental protection and know the operating instructions and the safety instructions.
- all safety instructions and warnings attached to the machine must not be removed and must remain legible.



The following instructions must be read carefully in order to avoid accidents to persons and / or property damage

- Never attempt to operate the machine before you have read and understood the content of this operation manual.
- If you are unsure about any points, please contact *GERIMA* for assistance.
- Make sure that all persons who will be operating or servicing the machine have read and understood all the relevant safety information.
- Before starting the machine, the operator must ensure that all safety equipment is properly installed and functioning correctly.
- Never use the machine for purposes other than those specified in this manual. Never use the machine to process materials other than those approved for use by the machine's manufacturer. If you are considering using the machine for an unapproved purpose, please first contact *GERIMA* to request approval of your proposed application.
- Check that all electrical connections are secure and sound. Never attempt to service or repair the machine before it has been disconnected from the power supply.
- Always use genuine *GERIMA* spare parts and accessories or those that have been approved for use by *GERIMA*.

If you encounter a problem or fault when operating the machine and you are unable to solve the issue with the aid of this manual, please contact *GERIMA* for rapid assistance.

Operator qualifications and protection of machine operators:

The term 'operator' is used here to mean any person who operates, adjusts, services and/or repairs the machine.

The employer is obliged to inform the operator about security relevant standards and to verify compliance.

To be trained operating personnel may initially work only under the supervision of an experienced person on the machine. Successful completion of training should be confirmed in writing.

All control and safety devices must always be operated only by trained personnel.

All persons carrying out work on the machine must read the operating instructions and confirm with their signature that they have understood the operating instructions.

The workplace must be well lit and provide sufficient space for safe working.



Before working with or on the machine, the operator must have become acquainted with the machine and must have read and understood this manual.

The operator must

1. ensure that all guard plates are in place and all safety mechanisms are functioning correctly before starting the machine.



2. not wear clothing or accessories (jewellery etc.) that could be get trapped in moving machine parts.

3. always wear protective clothing (non-slip shoes, ear protection, gloves and safety goggles).
4. observe all relevant safety instructions. If a problem arises, the operator must refer to this manual before continuing with his or her work.

Protective clothing:

When working on/with the machine always wear:



ear protectors,



safety goggles,



protective gloves,



safety shoes.

Requirements to be met by operating staff:

The machine may only be operated by appropriately trained persons who have been instructed in the use of the machine and are authorized to operate it.

Operators must have read and understood this operating manual and must act in accordance with it. The functions of the operating personnel, i.e. what an operator is or is not allowed to do, must be clearly specified.

Special qualifications are required for the following activities:

- **Commissioning:** The machine may only be commissioned by the manufacturer.
- **Operational training:** Training in the use of the machine must be provided either by the manufacturer or by persons who have received appropriate instruction.
- **Fault elimination:** Faults may only be dealt with by appropriately qualified technical staff or by the manufacturer's service personnel.
- **Maintenance:** Maintenance work may only be performed by technical staff who have received appropriate instruction.
- **Cleaning:** The machine may only be cleaned by persons who have received appropriate instruction.
- **Servicing:** The machine may only be serviced by appropriately qualified technical staff or by the manufacturer's service personnel.
- **Repair:** The machine may only be repaired by appropriately qualified technical staff or by the manufacturer's service personnel.
- **Decommissioning:** Decommissioning of the machine may only be performed by appropriately qualified technical staff or by the manufacturer's service personnel.

Risk of injury from hot metal chips:



- Hot chips are ejected from the machine at high speed.

Improper use can cause serious injury:



- Make sure you always have a firm footing when working with the machine.
- Never touch the milling tool when the machine is running.
- Never use the machine above head height.
- Ensure the switch is in the off-position before connecting to power source. After use de-energize the machine by disconnecting it from the power supply!
- Only Milling against the rotating direction = upcut milling

Improper use can damage equipment and property:



- Risk of machine being damaged or destroyed.
- Never lift or carry the machine by its power cable.
- Make sure the cable is directed behind and away from the machine. Do not lay the cable over sharp edges.
- Always use genuine *GERIMA* spare parts and accessories.



Risk of electric shock! Warning of physical injury by electricity

- All work on the machine's electrical systems must be performed only by qualified electrical technicians.
- Electrical equipment must be checked regularly.
- Any loose connections must be reattached and any damaged wires or cables replaced immediately.
- Never attempt to clean electrical equipment or systems with water or other similar liquids.
- Use only genuine replacement fuses that match the specified voltage and current.
- The machine should always be supplied with power via a residual current device (RCD) with a rated current of 30mA or less.

Machine hazards :

The machine has been built in accordance with the latest engineering standards and generally recognized safety principles.

Nevertheless, improper use can result in serious or fatal injury to the user and/or third parties or cause damage to the machine or other property.

The machine must only be used:

- For its intended purpose.
- If it is safe and in good repair.
- In compliance with the operating manual and by persons who are aware of the safety issues and hazards associated with the machine.
- Faults that could affect the safety of the machine must be remedied immediately.

Regular pre-start safety precautions



Perform the following pre-start procedures each time you plan to use the machine:

- Check and ensure that all of the machine's safety and protective equipment is in place and functioning correctly.
- Check the machine for visible signs of damage. Any defects or deficiencies identified must be remedied immediately or reported to the supervisor. The machine may only be used if it is safe and in a state of good repair.
- Check and ensure that only authorized persons are within the machine's work area and that no other persons can be endangered by switching on the machine.
- All objects and other materials that are not needed for the operation of the machine must be removed from the machine's work area.
- The measures to be taken in an emergency are known.

Basic Safety Measures for Normal Operation:



- The machine may only be started from the specified workstation.
- During operation of the machine safety devices must not be removed or rendered inoperable.
- The operator may be present only at the specified workplace during operation of the machine.
- The operator must ensure that no unauthorized persons are in the working area of the machine.
- After switching off the machine, the operator must wait until all moving parts have stopped and the lights are off function.

Maintenance:



Maintenance or service work must only be performed once the machine's moving parts have come to rest. Machine parts may become very hot during operation.

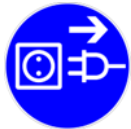

- De-energize the machine by disconnecting it from the power supply.

Machine hazard points:



Milling head

- Never touch the milling head when the machine is running.

Safety information for servicing, maintenance and fault elimination:

- Any person who installs, commissions, operates, inspects, services or maintains the machine must have read and understood the operating manual and in particular the safety information contained therein.
- Machine adjustment, maintenance and inspection work must be carried by appropriately qualified technical staff.
- Servicing and maintenance work must only be carried out by appropriately qualified technical staff.
- All operating equipment must be secured against accidental activation or energization.
- When performing any servicing, maintenance or repair work de-energize the machine by disconnecting it from the supply and ensure that the machine cannot be switched on again accidentally. Put up a warning sign prohibiting reactivation of the machine (lock and tag out procedure).

- If protective guards or other safety devices have to be removed for servicing or maintenance work, they must be reinstalled immediately after the work has been completed.
- Use only listed operating and auxiliary materials.
- Use only genuine spare parts as listed in the spare parts list.
- Check bolted connections for tightness.
- Before restarting the machine, make sure that nobody can be endangered by the running machine.
- Any unsafe operation is prohibited!
- Never put safety devices inoperative!
- Never wear hanging or protruding clothes which could become trapped in moving machine parts!
- After maintenance check all safety devices for function!

Consequences when nonobservance:



- Injury hazards for personnel!
- Damage to the machine!
- Modifications of the machine can affect the correct operation and safety of the machine!

Modifications to the machine:



The machine may not be modified, added to or converted unless the prior consent of the manufacturer has been granted.

Any alterations to the machine must have been approved by GERIMA GmbH. This also applies to the welding of the component parts.

Cleaning the machine and disposal information:



All substances and materials used must be handled appropriately and accordance with all relevant statutory provisions and legislation.

The machine must only be cleaned after it has been switched off!

Machine noise:

The continuous sound power level emitted by the machine at the installation site is greater than > 84 dB (A).



Operating personnel must wear ear protection!

Residual risks:

- The machine was plant and constructed with all suitable devices to guarantee the safety and health of the operator.
- The machine is covered to prevent the risk of contact with moving parts.
- However residual risks still exist.
- As already mentioned the cutting area is protected as far as possible but there is an opening portion through which the processing material must be introduced.
- It is possible that the operator reaches in this area with his hands.



Always keep your hands as far as possible away from the cutting area!



Always observe the safety rules to minimize the residual risks!



Be aware that the machine may be a source of residual mechanical or electrical energy. Appropriate precautions for dealing with these hazardous energy sources must be taken when instructing operating personnel on the use of the machine.

The hand-held beveling machine SMA 20 AEF-24.K1 / 14.K1 may only be used for work and materials described in the section ,intended use'.



Do not use the machine to work on materials containing asbestos!

The SMA 20-AEF is a hand-held, electrically powered beveling machine intended:

- For machining workpieces made of steel, cast steel, fine-grained steel, stainless steel, aluminium, aluminium alloy, brass and plastic.
- For commercial use in industrial settings and in the skilled-trades.
- For preparing K-, V-, X-, and Y-shaped welding grooves.
- For creating visible edges in plant and mechanical engineering work.
- For rounding off of edges for an optimal painting preparation or as a scratch and bump protection.

Replacing guiding roll / carbide inserts

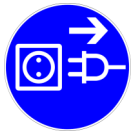

Before replacing always disconnect the machine from the power supply by removing the power cable from the socket !

1

Lock spindle

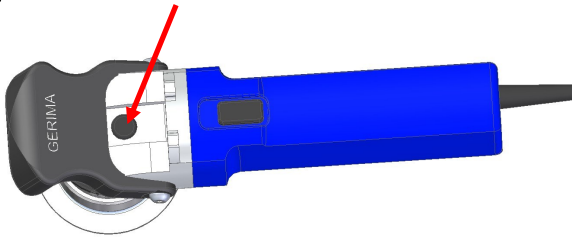

2

Loosen the guiding roll with screwdriver SW4 and pull out the guiding roll of the milling head.

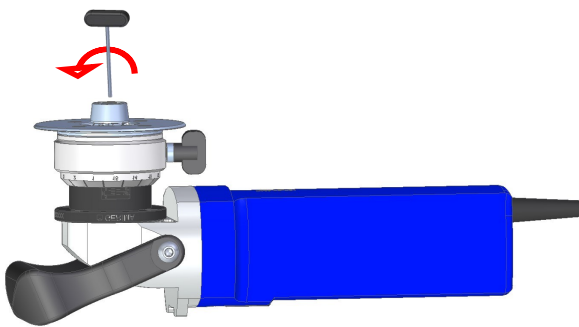

3

Then loosen the clamping screws with the Torx wrench T15 and replace the carbide inserts. The inserts must be fastened to the mounting seat on the milling head by means of the original locking screws (max. tightening torque: 4.0–5.0 Nm).

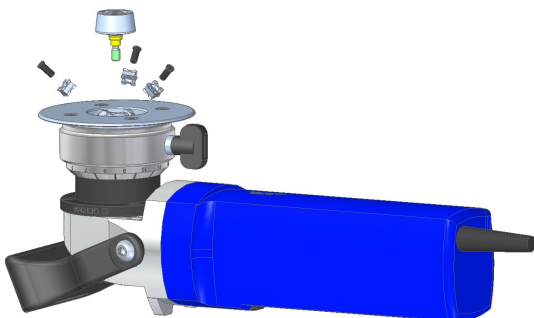

In order to avoid cuts and burns when carbide inserts change, carbide inserts only change to a complete stop of the machine. Use protective gloves!

Adjusting the 4-fold insert type MV and the 8 bevel and radius inserts (type SX and RSX):

The bevel and radius carbide inserts of type SX and RSX each have 8 cutting edges. By turning and turning, it is possible to use the cutting edges 8 times and the radius carbide insert up to 16 times. The MV carbide insert has 4 cutting edges each. By turning and turning, it is possible to use the indexable inserts four times.

Consumables and accessories

| nr. | name of part | order-nr. |
|-----|--|-------------------|
| 1 | Clamping screw CS-30-09 | 0101.203.16-00001 |
| 2 | Bevel-carbide insert MV4.B12-V1 | 0101.404.19-00058 |
| 3 | Bevel-carbide insert SX8.B12-V1 | 0101.404.20-00006 |
| 4 | Radius-carbide insert R1.2-SX16.B22-V1 | 0101.404.19-00063 |
| 5 | Radius-carbide insert R2.5-SX8.B22-V1 | 0101.404.19-00076 |
| 6 | Guiding roll (MV) GR45-17.63-MB1 | 0101.113.19-00003 |
| 7 | Guiding roll (SX) GR45-19.40-SB1 | 0101.113.19-00002 |
| 8 | Guiding roll (R1.2) GR45R1.2-26.10-SB2 | 0101.113.19-00004 |
| 9 | Guiding roll (R1.2) GR45R1.2-19.80-SB1 | 0101.113.19-00005 |
| 10 | Guiding roll (R2.5) GR45R2.5-21.69-SB1 | 0101.113.19-00006 |
| 11 | Torx-wrench T15 | 0000.077.14-00001 |
| 12 | Screwdriver SW4 | 0000.077.15-00014 |



milling bodies with special angles and radii on request

Setting the bevel length:

- a leg length = bevel length a
- b leg length = bevel length b
- C bevel width
- α bevel angle
- β opposite angle
- A bevel size
- h bevel height
- S residual bridge
- t plate thickness

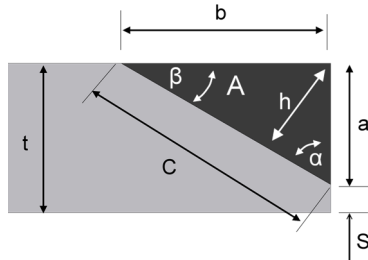

The bevel length (a) is setting by adjusting the position of guiding plate (1). The height setting can be read out at the main scale (2) and the vernier collar (3). Loosen the clamping lever (4) and rotate the guiding plate (1) until the required bevel length has been set as shown by the main scale (2) in combination with the verniere scale on the collar (3). Retighten the clamping lever (4).

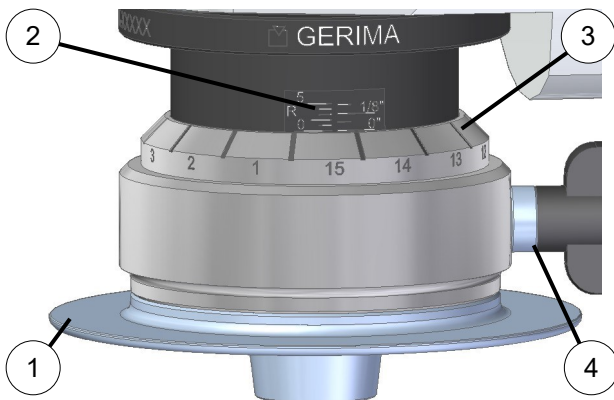

Once the bevel height has been set, a bevel should be milled on a test sample to check whether further height adjustments are required. These may be necessary because the precision of the scale is approx. ± 1 mm.

The values above are experical values, no guarantee values!

Some materials can harden on the edges of the workpiece when working with flame cutting, plasma, laser cutting. This can result in significant deviations from the specified reference values.

Adjusting radius:

The procedure for setting the radius and bevel is identically. Please note that only the position of the upper edge of the radius can be adjusted by rotating the guiding plate. The lateral position of the radius on the workpiece end face is determined by the guiding roll fitted and cannot be altered.

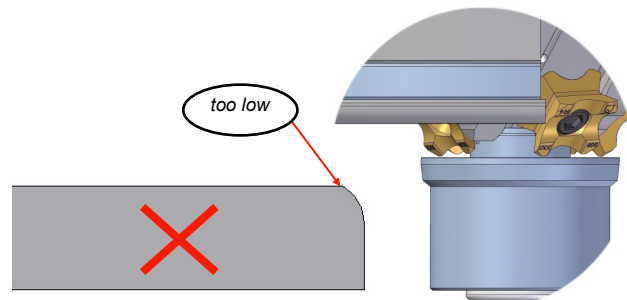

Guiding plate set too low (radius incomplete).

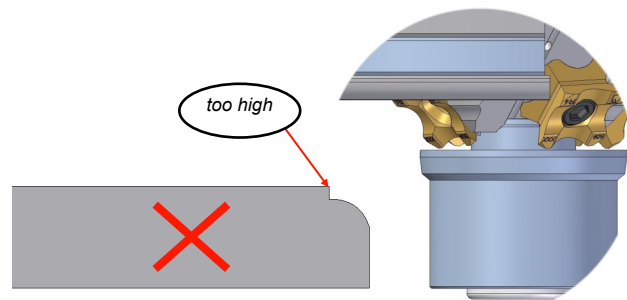

Guiding plate set to high (radius cuts into material).

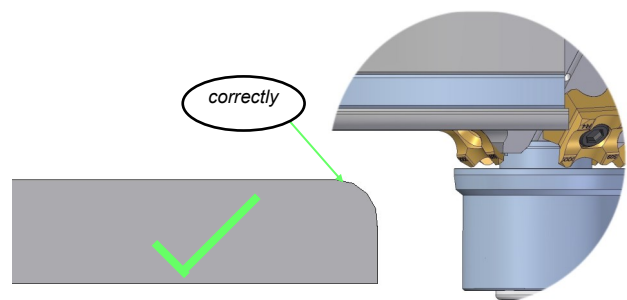

Guiding plate set correctly (radius fully formed with smooth transition to workpiece surfaces.)

General:



Two-handed operation:

Whatever the position of the machine, always use two hands to control the machine.

When working with the machine, make sure that the machine is always held with two hands (see red arrows) and in such a way that both hands are kept away from the machining point.

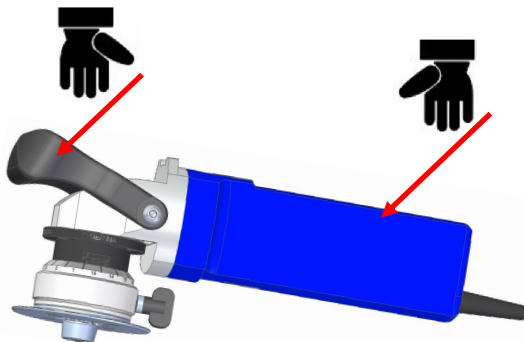

Ensure that the workpiece is securely clamped!



- for safety reasons
- to improve the service life of the carbide inserts
- to prevent damage to the milling machine

Important!

Before machining a workpiece, make sure that it is securely clamped so that it cannot slip.

This should be done to ensure safe working so that the workpiece does not slip or even fly off when being milled and to prevent unnecessary vibrations in the workpiece material.

The less vibration generated in the workpiece, the longer the service life of the carbide inserts.



To become acquainted with the machine, you must start by machining a small bevel with a width of no more than 2 mm and remember to advance the machine slowly first. Bevels of maximum width can only be machined safely and reliably once you have become used to handling the machine.

Handling:



Damages caused by wrong power supply!

- Check the supply voltage. The supply voltage must correspond with the specifications on the type plate of the machine.



Improper use can cause serious injury!

- Make sure you always have a firm footing when working with the machine!
- Never touch the milling head when the machine is running!
- Always lead the machine away from body during working, never use the machine above head height.



Risk of damage to equipment and property!

- Working with worn or damaged carbide inserts or milling heads will cause the machine to fail!
- Avoid collisions when working with the machine!

Working with the machine:

Press on-/off-switch (1) until it clicks into place!

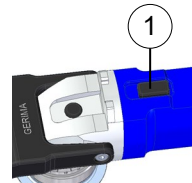

Motor starts

Bring the machine slowly into contact with the workpiece only after the selected tool speed has been reached.

Machining the workpiece (up-cut milling)

When milling a bevel always move the machine from left to right against the direction of rotation of the milling head (up-cut milling).

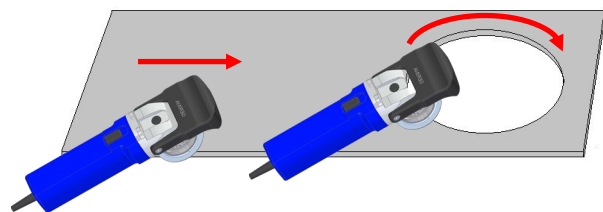

Switching off the machine

- remove the machine from the workpiece.
- press the on-/off-switch.
- once the motor is switched off, wait for it to come to a standstill before placing the machine down on a surface.

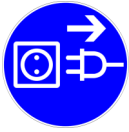
Maintenance

Before serving the machine always disconnect the machine from the power supply by removing the power cable from the socket !



Repair must only be carried out by a GERIMA trained technician!



Improperly repaired machines are hazzard!

- Increased risk of injury
- Machine does not function correctly!



Hot carbide inserts and milling head!

- Burn hazzard!
- Wear protective gloves when replacing the carbide inserts!

Blunt tool can cause damage!



- Blunt tool can overload the machine!
- Inspect milling tools regularly for signs of wear.
- Wear protective gloves when changing or readjusting the carbide inserts!

Maintenance plan:

| Part to be serviced | Type of maintenance work | Service | Maintenance procedure | Materials required | Order-nr. |
|--|----------------------------------|--------------------|--------------------------------|------------------------------|-------------------|
| Service 1: Ventilation slots | Daily | Machine operator | Clean ventilation slots | Brush, cloth, compressed air | |
| Service 2: Height adjuster thread | Clean and lubricate as necessary | Trained technician | Disassemble guiding plate unit | Teflon spray | 0109.007.10-00005 |
| Service 3: Carbide inserts | Rotate or replace as necessary | Machine operator | See page 14 | Torx-wrench T15 | See page 14 |

Service 1:

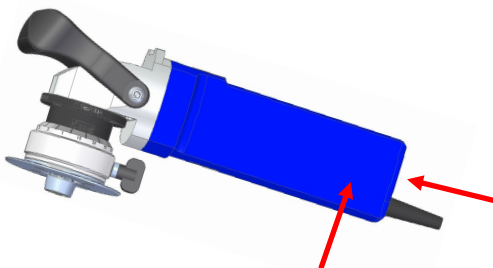
To ensure that the machine can be cooled properly, the ventilation slots must be kept clean. To avoid damaging the motor winding it is important that no foreign matter (e.g. chips) enter the motor compartment. Clean the motor compartment regularly by blowing compressed air through it.

Service 2:

Remove the screw for height clamping, lift the guiding plate unit, clean the mounting thread, lubricate the thread with teflon spray and then re-assemble in reverse order.

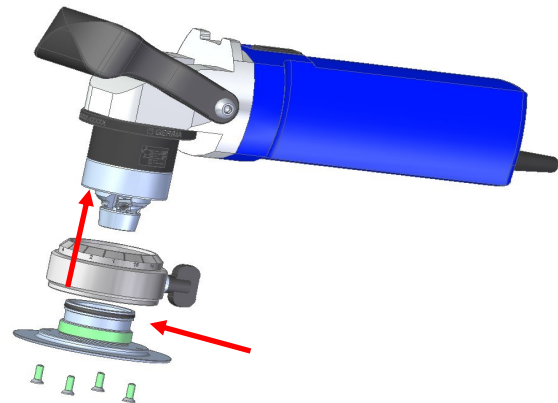
Disposal of components removed from the machine:

All machine parts, operating and auxiliary materials must be disposed of in accordance with the applicable statutory provisions.

Assembly group SMA 20 AEF-24.K1 / -14.K1

0202-20-00-00-00-06

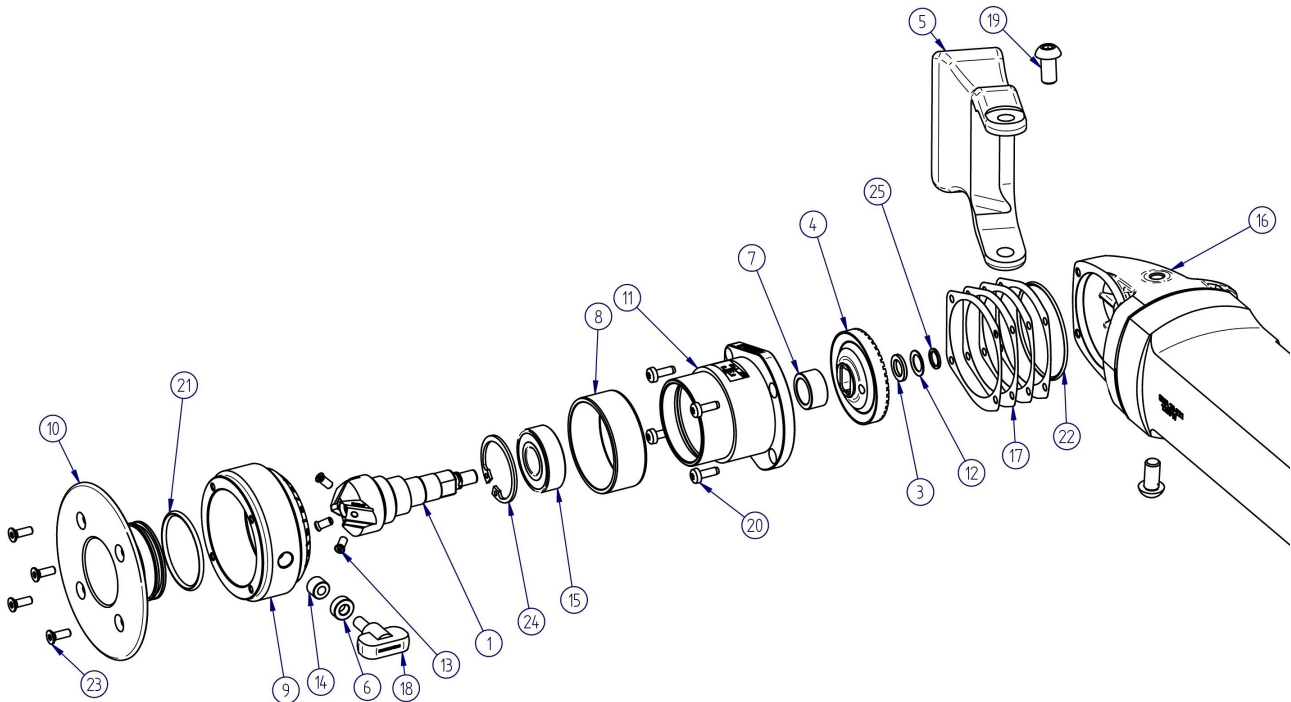

| nr. | name of part | order-nr. | pc. |
|-----|-------------------------------|-------------------|-----|
| 1 | Spindle with milling head 45° | 0101.112.19-00010 | 1 |
| 3 | Distance disc | 0101.112.19-00011 | 1 |
| 4 | Bevel gear | 0101.112.19-00009 | 1 |
| 5 | Handle | 0101.112.15-00015 | 1 |
| 6 | Distance-ring | 0101.112.15-00016 | 1 |
| 7 | Distance-ring | 0101.112.15-00017 | 1 |
| 8 | Steel bush | 0101.112.15-00006 | 1 |
| 9 | Counter-ring | 0101.112.15-00005 | 1 |
| 10 | Guiding plate | 0101.112.15-00004 | 1 |
| 11 | Gearbox | 0101.112.15-00003 | 1 |
| 12 | Disc spring | 0101.112.15-00012 | 1 |
| 13 | Clamping screw CS 30-09 | 0101.203.16-00002 | 3 |
| 14 | Nut insert | 0101.243.08-00012 | 1 |
| 15 | Groove ball bearing | 0000.012.14-00040 | 1 |
| 16 | Drive unit 1.200W / 230 V | 0101.112.15-00009 | 1 |
| 16 | Drive unit 1.100W / 110 V | 0101.112.15-00023 | 1 |
| 17 | Spacer | 0101.112.15-00011 | 4 |
| 18 | Wing screw | 0000.032.14-00056 | 1 |
| 19 | Hexagon socket screw M8x16 | 0000.022.15-00018 | 2 |
| 20 | Fillister head screw M4x12 | 0101.112.15-00013 | 4 |
| 21 | O-ring | 0000.042.15-00002 | 1 |
| 22 | O-ring | 0000.042.15-00001 | 1 |
| 23 | Countersunk screw M4x12 | 0000.022.14-00190 | 4 |
| 24 | Locking ring | 0000.022.15-00005 | 1 |
| 25 | Retaining ring | 0000.022.15-00017 | 1 |

GERIMA shall guarantee a new machine for a period of twelve months beginning on the date the machine was purchased from the *GERIMA* production facility in 66606 St. Wendel, Germany.

Any further guarantees shall require the prior written agreement of both the machine owner and the manufacturer.

The guarantee provides that the machine is free from defects in materials and/or workmanship. Any performance data contained in information or promotional materials or included in quotations are understood to be for guidance only and are not guaranteed, as these values depend very strongly on the material worked and the particular machining operation used.

Any guarantee claim submitted must state the machine identification number and must be accompanied by the relevant delivery note or invoice.

Repairs under guarantee may only be carried out by *GERIMA* or by one of its authorized specialist retailer or representatives.

Guarantee claims can be made only for genuine *GERIMA* parts and if the machine was used for its intended purpose. The guarantee does not cover, in particular: operational wear and tear; improper use; partially or wholly disassembled machines; damage arising from overloading the machine or from the incorrect use of the milling tool; the use of non genuine, unauthorized or defective parts; damage caused by the machine to the workpiece; use of excessive force; consequential damage arising from improper or inadequate maintenance by the customer or a third party; damage caused by unauthorized third parties or by the presence of foreign matter; damage arising from a failure to comply with the manufacturer's operating instructions, e.g. connecting the machine to the wrong power supply.

Services provided under the guarantee are understood to be 'ex works' (66606 St. Wendel, Germany).

Any additional costs, such as travel costs for technical personnel, shipping costs etc. are not covered by the guarantee and will be charged.

After receiving a defective machine, *GERIMA* shall compile a cost estimate of the repairs and shall provide notification of the extent to which these repairs are covered by the guarantee.

Once accepted, the machine will be repaired and then either dispatched with invoice or stored ready for collection.

**Declaration of Conformity in accordance with the EC Machinery Directive,
Annex II, 1A**

Translation — EC Declaration of Conformity

Manufacturer

GERIMA GmbH
Phone no: (0049) 6851-93951-70
Fax: (0049) 6851-93951-21
E-Mail: info@gerima.de
Internet: www.gerima.de
Weimarer Straße 12
66606 St. Wendel
Germany

Authorized representative according to MRL

GERIMA GmbH
Phone no: (0049) 6851-93951-70
Fax: (0049) 6851-93951-21
E-Mail: info@gerima.de
Internet: www.gerima.de
Weimarer Straße 12
66606 St. Wendel
Germany

Authorized representative technical documents

Dipl.-Ing. Stephan Rieth
GERIMA GmbH
Phone no: (0049) 6851-93951-70
Fax: (0049) 6851-93951-21
E-Mail: info@gerima.de
Internet: www.gerima.de
Weimarer Straße 12
66606 St. Wendel
Germany

Product
Product

SMA 20 AEF-24.K1, 21-240-****, 00001-99999, 2021
SMA 20 AEF-14.K1, 21-241-****, 00001-99999, 2021

We hereby declare that the above mentioned product complies with all relevant provisions of the Machinery Directive 2006/42/EC.
The above product fulfills the relevant requirements of the following guidelines:

- ▶ Directive 2006/42/EC of the European Parliament and the Council of 17 May 2006 on machinery and amending Directive 95/16/EC (recast) 2006/42/EC
- ▶ Directive 2006/95/EC of the European Parliament and the Council of 12 December 2006 to approximate the laws of the Member States relating to electrical equipment designed for use within certain voltage limits 2006/95/EC
- ▶ Directive 2004/108/EC of the European Parliament and the Council of 15 December 2004 to approximate the laws of the Member States relating to electromagnetic compatibility and repealing Directive 89/336/EEC 2004/108/EC

and corresponds to the following standards:

- ⇒ **DIN EN 60745-1/A11 VDE 0740-1/A11:2011-09**
Hand-held motor-operated electric tools - Safety
Part 1: Generell requirements
German Version EN 60745-1:2009/A11:2010

St. Wendel, 01.01.2021



Dipl.-Ing. Stephan Rieth, Business Management