

# ***INSTRUCTION MANUAL***

## **AIR HAMMER**

Please read this manual carefully before you attempt to use your tool so that you may use it properly and safely.

## **AUTO CHISEL PROFESSIONAL TOOL**

**Model A-300**



### **Specifications**

<b>Model</b>	<b>A-300</b>
Maximum Operating Pressure	0.6 MPa
Air Consumption (No Load)	0.3 m <sup>3</sup> /min
Rated Speed (No Load)	2600 min <sup>-1</sup>
Sound Pressure Level	97 dB(A)
Sound Power Level	108 dB(A)
Vibration Level	≥ 30 m/s <sup>2</sup>
Chisel Shank Dia.	10 mm
Mass (Weight)	1.7 kg
Thread Size of Air Inlet	Rc1/4

Due to continuous product development/improvement the specifications and configurations in this document are subject to change without prior notice.



Manufactured by :

**NITTO KOHKI Co., Ltd.**  
2-9-4, Nakaikegami, Ohta-ku,  
Tokyo, 146-8555, Japan  
TEL : (81)-3-3755-1111  
FAX : (81)-3-3753-8791  
E-mail : [overseas@nitto-kohki.co.jp](mailto:overseas@nitto-kohki.co.jp)  
URL : [www.nitto-kohki.co.jp](http://www.nitto-kohki.co.jp)

**Keep the manual handy – so you can use it whenever necessary.**

Original Instructions

Thank you very much for your purchase of this **Nitto Kohki products.**







Before using your tool, please read this manual carefully so that you may use it properly to get the most out of it.

**Please keep the manual handy - so you can use it whenever necessary.**



- **English** : Please ask your dealer or distributor for instruction manual in local language(s).
- **German** : Bitte fragen Sie Ihren Händler nach eine Betriebsanleitung in Landessprache.
- **French** : S'il vous plait, veuillez demandez á votre fournisseur de manuel instruction en langue locale.
- **Spanish** : Por favor, contacte con su distribuidor para el manual de instrucciones en español.
- **Portuguese** : Por favor pessa ao seo agente ou distribuidor o manual de instrucces ih linguagen local.
- **Italian** : Per Manuale Istruzioni in lingua locale Vi preghiamo di rivolgervi al rivenditore o distributore.
- **Dutch** : Vraag uw handelaar om een nederladstalige gebruiksaanwijzing.
- **Swedish** : Be er lokala Åtreförsäljare eller distributör om manualer på svenska.
- **Danish** : Venligst henvend Dem til den danske distributør for instructions manualer.
- **Polish** : Proszę pytać swojego dealera lub dystrybutora o instrukcje obsługi w języku localnym.
- **中文** : 請向當地供應商或經銷商詢問中文使用說明書

<b>CONTENTS</b>	<b>page</b>
IMPORTANT SAFETY INSTRUCTIONS .....	2
GENERAL: TOOLS .....	2
GENERAL: PNEUMATIC TOOLS .....	3
INSTRUCTIONS FOR THIS TOOL .....	3
1. USAGE .....	4
2. CHECK THE CONTENTS OF THE PACKAGE .....	4
3. AIR SUPPLY .....	4
4. PREPARATION .....	4
5. HOW TO OPERATE THE TOOL .....	5
6. MAINTENANCE AND INSPECTION .....	6
7. THEREAD SIZE OF HOSE FITTING .....	6
8. STORAGE .....	6
9. ORDERING SERVICE PARTS .....	7
10. TYPE OF CHISELS AND THEIR APPLICATIONS .....	7
11. EXPLODED DIAGRAM : A-300 .....	7

### PICTOGRAM

-  Warning: It might be dangerous to operate the tool if the instructions supplied are not followed.
-  Using this tool improperly could result in serious injury. Read the instruction manual before using.
-  Always wear suitable eye protection.
-  Always wear suitable hearing protection.
-  Always wear respiratory protective equipment (PPE).
-  Always wear protective gloves for protection of hands from Vibration and Shock.

The following Safety notations are used throughout the manual to highlight safety precautions for the user and for the tool.

 <b>Warning:</b>	Indicates a potentially hazardous situation which, if not avoided by following the instructions given, could result in death or serious injury.
 <b>Caution:</b>	Indicates a potentially hazardous situation which, if not avoided by following the instructions given, could result in injury or material damage.

Please note, however, that failure to observe safety precautions under the “ **Caution**” category could result in a serious occurrence depending on the situation: please observe all safety precautions in the manual.

**Caution:** Important precautions for tool setup, operation and maintenance.

# IMPORTANT SAFETY INSTRUCTIONS

When using the tool, please observe the safety precautions below to prevent possible accident or injury.

## GENERAL: TOOLS

### WARNING

#### TO OPERATORS

- **Wear proper clothing for the type of work being done.**  
Take care so that clothing, ties, hair, etc. will not become entangled with the moving parts. If items become entangled it will cause the operator to be pulled towards the tool and lead to possible cause of accident or injury.
- **Always wear suitable eye protection.**  
Vision correction glasses are not safety glasses. Always wear appropriate safety glasses when doing your job.
- **Always wear suitable hearing protection.**
- **Wear respiratory protective equipment (PPE).**  
Wear respiratory protective equipment (PPE) when working in an environment where dust particles are generated in operation.
- **Always wear suitable protective gloves.**
- **Avoid working posture that is too stressful.**  
Always ensure a firm footing and well balanced posture.
- **Do not operate the tool if you are too tired.**
- **Never touch any moving parts of the tool when running.**

#### ABOUT WORK AREA

- **Keep the work area clean.**  
Cluttered work areas (e.g. workbench) invite accidents.
- **Carefully select the work area.**  
Do not expose tool to rain.  
Do not use tool in a wet or soaked area.  
See that the work area is adequately illuminated.
- **Never work near inflammable liquid or in a potentially explosive atmosphere.**
- **Keep children away from the work area.**  
Keep children and unauthorized people away from the work area to avoid accident or injury.

#### BEFORE OPERATION

- **Inspect tool before use.**  
Before using, check that screws are securely tightened, that any protective cover or guard is securely in place, other parts are free from damage and that the tool runs as it should.  
Check that moving parts are properly adjusted for positioning and tightened, that parts are free from damage and properly mounted, and that all other parts are in good condition for normal operation.  
Should you find any damage to the protective cover or other part, replace it in accordance with the Operation Manual. If there are no instructions in the Manual, please contact the sales agent through which you have purchased your tool or an authorized dealer near you for repair.  
Likewise, if a switch failure occurs, contact sales agent through which you have purchased your tool or an authorized dealer near you for repair. .  
Do not use the tool if it does not start or stop with the start/stop switch.
  - **Securely mount cutter**  
An improperly mounted cutter may fly out, causing possible damage to the tool or injury to the operator.
  - **Always remove spanner, wrench, etc., once adjustment has been made with them.**
  - **Use a tool appropriate for the application.**  
Avoid heavy-duty application that is beyond the capacity of tool.
  - **Do not use the tool for purposes other than what it is designed for.**
  - **Do not abuse tool.**  
Use tool in accordance with the specifications: you'll get the most out of it while ensuring safety.
  - **Securely fasten workpiece in place.**  
Use a vice or clamp to securely fasten the workpiece in place. It is much safer this way than holding it in your hand, allowing you to operate the tool with both hands.
- #### ABOUT HANDLING
- **How to store tool.**  
When the tool is not used, store it in a dry area and out of reach of children.
  - **How to carry tool.**  
Do not touch the start switch while the tool is being carried.
  - **Do not leave the tool unattended while it is running.**  
Turn off the start switch and disconnect the tool from

power source. Do not leave the work area until the tool comes to a complete stop.

### MAINTENANCE/SERVICE

- **Do not take apart or modify tool.**  
Disassembly or modification carried out without the supervision of a qualified or authorized service engineer could result in an accident or injury.
- **Inspect cutting tool and accessories, etc.**  
Always check to see that cutting tool and accessories, etc. are in good operating condition without damage or deterioration before you mount them on the tool. Should you find any damage to an accessory or part, please contact sales agent through which you have purchased your tool or an authorized dealer near you for repair.
- **Check parts for damage.**  
When you have found damage to accessory or other part, carefully check the damaged part to determine the extent of influence it has upon the functions of the tool – that is, determine whether it can still perform its normal functions.  
Check to see that the linkage of the moving parts is OK, that all parts are OK without damage, that they are properly mounted, and that the tool functions normally. Should you find any damage to an accessory or part that may hamper proper functioning of the tool, please contact sales agent through which you have purchased your tool or an authorized dealer near you for repair.
- **Have your tool repaired at an authorized Nitto Service Center.**  
For repair or parts replacement, please contact the sales agent through which you have purchased your tool or an authorized dealer near you.
- **Use only Nitto genuine parts.**  
Use of improper parts may result in serious accident. To obtain a Nitto genuine part, consult this Manual or contact the sales agent from which you have purchased your tool directly.
- **Do not detach label or nameplate from tool.**  
When a label/nameplate gets damaged, worn or becomes missing, contact the sales agent through which you have purchased your tool or Nitto Kohki Co. Ltd, directly for a replacement.

### DISPOSAL

When a tool is taken permanently out of service, it is advised that the tool is disassembled, degreased and parts separated by material and recycled locally in the appropriate manner.

## GENERAL: PNEUMATIC TOOLS

### WARNING

- **Use appropriate air pressure.**  
Excessively high air pressure will increase the tool number of revolutions or strokes causing not only potential premature failure/breakage but could also lead to an unexpected accident or injury.
- **Connect tool to air supply line.**  
There are various types of pipes running in a factory in addition to the pneumatic line (such as oxygen, nitrogen, gas and water). For this reason, always ensure that you are connecting to the pneumatic line.
- **Start tool properly.**  
Turn the start switch OFF before connecting to the air supply line.
- **Always disconnect the tool from the air supply line before putting on/taking off any accessory and prior to carrying out any maintenance work.**
- **Avoid exposure to exhaust air.**  
Pneumatic tool exhaust air contains oil and contaminated moisture. Make sure the exhaust air is not directed towards your face or anyone else within the work area.
- **Keep tool off electricity.**  
This pneumatic tool is not electrically insulated. To avoid a potential electric shock do not use where there is a possibility of coming into contact with live electricity.

### CAUTION

- **Handle tool carefully.**  
Abusive use of tool could invite failure or accident. Do not throw, drop or shock the tool.
- **Handle air hose carefully.**  
Do not carry the tool by the air hose. Do not pull the air hose to disconnect.

# INSTRUCTIONS FOR THIS TOOL

## About Your Tool

### WARNING

- **Wear protective glasses and a dustproof mask** operation generates chips and dust particles, etc. which may cause eye and/or respiratory injury: Always use PPE (Personal Protective Equipment) for eye and respiratory protection.
- **Wear vibration reducing and shock absorbing gloves.**  
This is a power tool utilizing vibration. Wear vibration reducing and shock absorbing gloves. When your hands, fingers, arms, etc. feel discomfort during operations, immediately stop your work. Long hour operation should be prohibited, for it may cause Vibration - Induced disorder.
- **Always wear suitable hearing protection.**  
The tool generates loud noise. Always use ear plugs for hearing protection. Take necessary measures to comply with the local regulatory requirements and laws with regard to noise level, or do better.
- **Do not operate tool at no load.**  
Do not operate the tool at no load: It may not only cause damage to the tool but also may cause chisels to fracture and fly out, possibly resulting in unexpected accident.
- **Be sure to keep hands clear of chisel edge.**
- **Fix the chisel firmly. If the chisel is not fixed firmly, it may jump out and cause injury.**

## 1. USAGE

This tool is for chipping work pieces with a chisel.

## 2. CHECK THE CONTENTS OF THE PACKAGE

Check the contents and make sure that the tool does not have any damage which may have occurred during transportation. The contents should correspond to the list as follows. In case of damage/missing parts, please contact the sales agent from whom you purchased the tool.

Package Contents	Qty	Check
A-300	1	
Bushing R1/4xNPT1/4	1	
Hose Nipple R1/4x1/4	1	
Instruction Manual	1	
Declaration of Conformity	1	
Caution for Use	1	

## 3. AIR SUPPLY

### 3-1. Air Pressure

Adjust air pressure with the air regulator to the level appropriate for the pneumatic tool used.

Air pressure that is too low will fail the tool to operate at full capacity

Air pressure that is too high may cause damage to the tool.

### 3-2. Air Line (Fig.1)

Use a 9.5mm (3/8") I.D. connecting hose between the compressor and the tool.

Drained water, etc., if flown into the tool, could cause tool failure. Install an air filter, between the compressor and the tool.

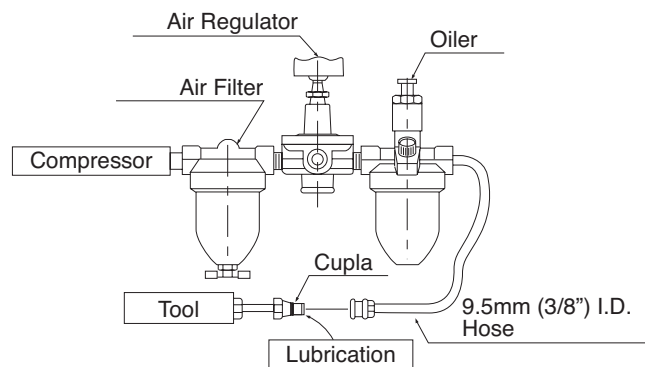

Fig. 1

### 3-3. Lubrication

Install an oiler between the compressor and the tool. Use the machine oil ISO VG-10. Failure to lubricate as required may result in damage to the tool. Use of oil that is too thick will reduce the performance of the tool.

### 3-4. Short hose fittings

Do not fix a coupling directly on the tool. Make sure that after a short hose is fixed with the Hose Nipple R1/4X1/4 including in the accessories, then the coupling be attached. If the couplings directly fixed, it would be damaged by the vibration and the life would be shortened.

## 4. PREPARATIONS

### WARNING

**Turn off the air supply and disconnect the air hose before preparation for use.**

### 4-1. Fixing the Attachment (Fig.2)

Fix the Hose Nipple to the Bushing (M16XRc1/4) of



the tool.

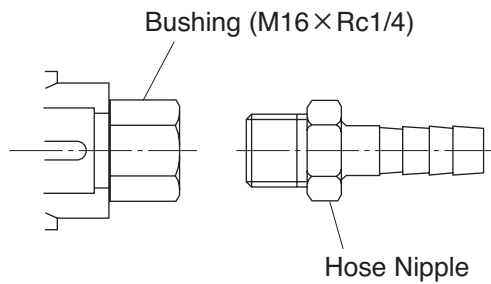

Fig. 2

#### 4-2. Replacing Chisels

- (1) Turn the Chisel Spring counterclockwise and remove it. (For removal, hold the spring A and turn it in such a way that it is loosened)
- (2) Change the Chisel and reassemble vice versa.
- (3) To mount the Chisel, insert the Chisel and lock the Chisel Spring by turning it clockwise to prevent the Chisel from being withdrawn.

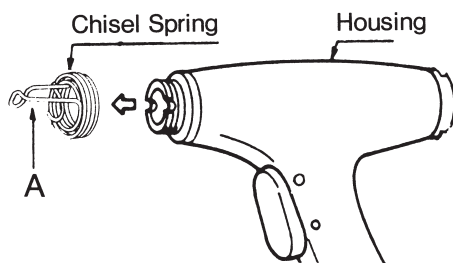

Fig. 3

### 5. HOW TO OPERATE THE TOOL

#### ⚠ WARNING

Do not operate tool at no load.

#### 5-1. Start and Stop (Fig.4)

- (1) Before connecting to the air hose, make sure that the Trigger is in OFF position.
- (2) To start, hold the machine and grasp the Trigger
- (3) To stop, leave the hand off the Trigger.

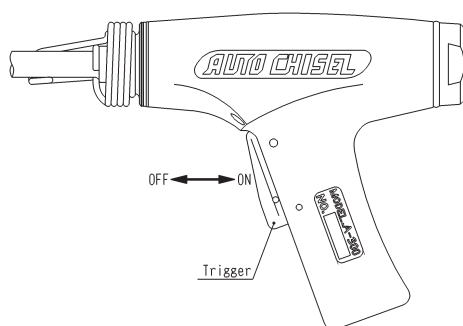

Fig. 4

#### 5-2. To prevent the chisel jumping (Fig.5)

To prevent the Chisel jumping (Fig.5)

First, grasp the grip and place the Chisel to the work. Gradually press the Trigger and 90 to full operation after the cutting position has been determined. The Chisel should not jump off the work.

Use the hand holding the valve body to press gently and guide the Chisel so that it does not come away from the work

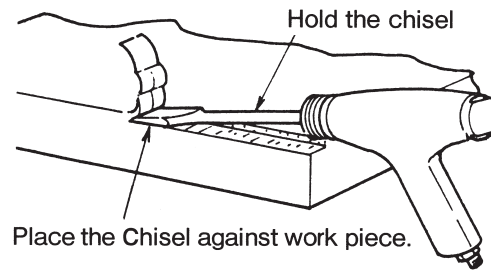

Fig. 5

### 6. MAINTENANCE AND INSPECTION

When reshaping the edge of the Chisel, apply water sometimes so that it may not be heated too much.

### 7. THREAD SIDE OF HOSE FITTING

The product comes with a metal-fitting with R thread. Connect the Bushing R thread X NPT thread included as standard accessories. If you would like to have American NPT thread instead.

### 8. STORAGE

#### ⚠ CAUTION

When tool is not used, store it out of children.

Avoid storing the tool in a location subject to high humidity, if the tool is left as it is used, residual moisture on the inside can cause rusting. Before storing, and after operation, oil the tool at the air inlet with machine oil ISO VG-10 and run it for a short time.

### 9. ORDERING SERVICE PARTS

For further operational and handling information or for replacement of parts and components, contact the company from whom you purchased the tool or an authorized dealer.

In ordering parts and components give each part number, part name and quantity required.

Use only NITTO genuine parts.

## 10. TYPE OF CHISELS AND THEIR APPLICATIONS

Please order with the chisel numbers below.

### No.1001 Blank Chisel

Bending iron plate, removing king pins.

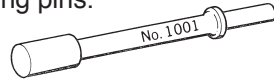

### No.1002 Flat Chisel

Puts increased efficiency into scraping, peeling spot welds, and cutting off bolts and pins.

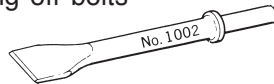

### No.1003 Sheet Metal Chisel A

Cutting iron sheets, body panels of automobiles.

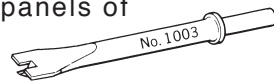

### No.1004 Sheet Metal Chisel B

Just for cutting off sheet metal body panels.

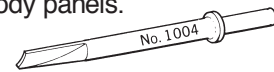

### No.1005 Silencer Cutting Chisel

A quick cut-off chisel for muffler piping.



### No.1006 Rubber Bushing Remover

Helps you remove idle arm sleeves and bushing very quickly.

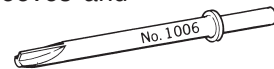

### No.1007 Spot Weld Booster

This chisel is ideal for peeling off spot welded points and cutting off pins.



### No.1008 Bushing Tool

Puts speed and ease into the job of bushing insertion.

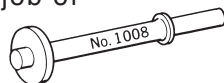

### No.1009 Punch

For driving out pins, rivets, and fitting and removing bearings and bearing races.



### No.1010 Bushing Removing Tool

A faster and suitable tool in removing bushings.



### No.1011 Sheet Metal Punch

Opens holes for bolts and rivets.



### No.1012 Bending Chisel

Helps the serviceman in peeling and removing slag around welds.



### No.1013 Fork Chisel 24

Disconnecting tie rod ends and ball joints.



### No.1014 Panel Crimper

Bending sheet metal: external body plates, doors, fenders, etc.

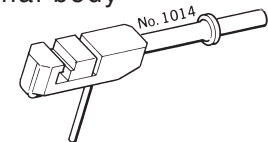

### No.1016 Fork Chisel 35

Disconnecting tie rod end ball joints.

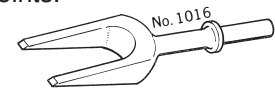

### No.1017 Fork Chisel 15

Disconnecting tie rod end ball joints.

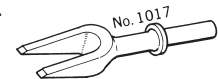

### No.1018 Scraper 38mm

Peeling off paint & removing rust from iron plate.



### No.1019 Scraper 60mm

Peeling off paint & removing rust from iron plate.

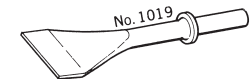

### No.1020 Concave Scraper 60mm

Removing incrustation from pipe.



### No.1023 Sheet Metal Chisel C

Cut shapes in sheet metal fast.



### No.1024 Moilpoint Chisel

Breaking up concrete, removing sand from cast-ings.

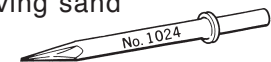

### No.1025 Rivet Removing Punch

Removing rivets from brake lining of heavy duty cars.

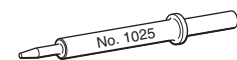

### No.1026 Rivet Caulking Chisel

Caulking brake lining of heavy duty cars.



## 11. EXPLODED DIAGRAM: A-300

### Warning

This diagram is for your reference only. Do not attempt to service or repair the Tool.  
 Do not take the Tool apart. Contact an authorized Nitto dealer for all service and repair of the Tool.  
 Improper service and repair can cause accidents and service injuries.  
 Never attempt to modify the Tool.  
 Never attempt service or repair the Tool yourself.

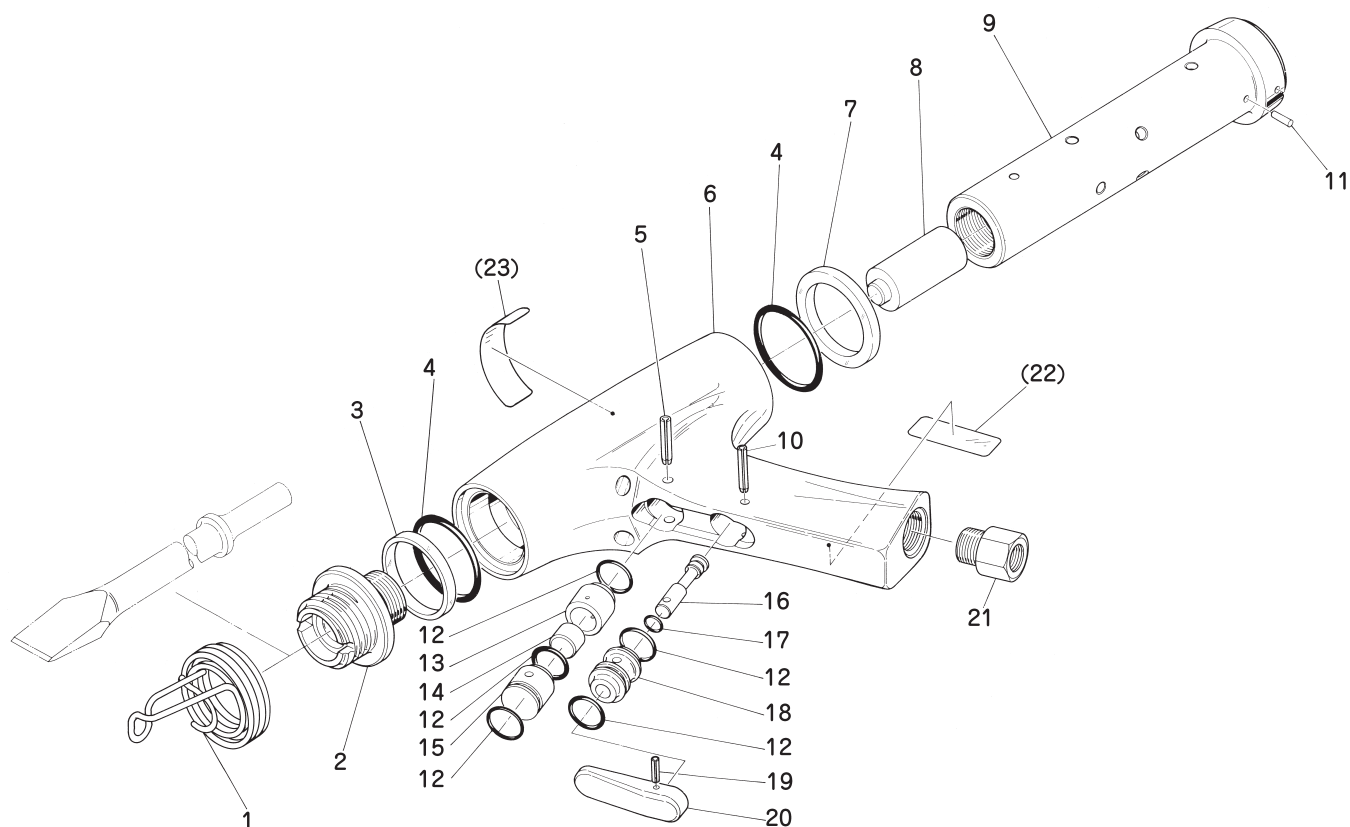

The part numbers with ( ) are included in the Ass'y parts written above them.

No.	Part No.	Description	Qty	Price
1	TP02308	Chisel Spring	1	
2	TP02791	Chisel Guide	1	
3	TP02300	Front Cushion	1	
4	TP11995	O-Ring P-31.5	2	
5	TP08389	Spring Pin 4×24	1	
6	TB08769	Housing Sub Ass'y	1set	
22	(TQ12611)	Label CE Mark	1	
23	(TQ12830)	Label Warning	1	
7	TP02312	Rear Cushion	1	
8	TP00597	Piston	1	
9	TA90793	Cylinder Ass'y	1set	
10	TP00460	Spring Pin 3×22	1	
11	TP08932	Spring Pin 4×8	1	
12	TP11996	O-Ring KS-10	5	
13	TP02302	Valve Case	1	

No.	Part No.	Description	Qty	Price
14	TP02309	Spool	1	
15	TP02303	Valve Stopper	1	
16	TP02306	Throttle Valve	1	
17	TP11994	O-Ring P-4	1	
18	TP02305	Valve Guide	1	
19	TP02310	Spring Pin 3×12	1	
20	TP02304	Trigger	1	
21	TP00857	Bushing M16×Rc1/4	1	

#### Accessories

No.	Part No.	Description	Qty	Price
	TP02236	Bushing R1/4×NPT1/4	1	
	CP02961	Hose Nipple R1/4×1/4	1	
	TQ12831	Instruction Manual	1	
	TQ12832	Declaration of Conformity	1	



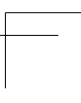
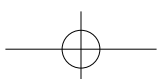
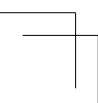
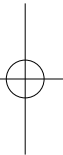
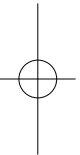
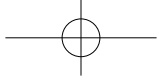
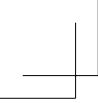



Overseas Affiliates / Offices

NITTO KOHKI U.S.A., INC.
46 Chancellor Drive, Roselle, IL 60172 U.S.A.
Tel:(1)-630-924-9393 Fax:(1)-630-924-0303

NITTO KOHKI EUROPE CO., LTD.
Unit 21, The Empire Centre Imperial Way,
Watford Herts, WD24 4TS, U.K.
Tel:(44)-1-923-239668 Fax:(44)-1-923-248815

NITTO KOHKI DEUTSCHLAND GMBH
Lerchenstr.47 D-71144 Steinenbronn, Germany
Tel:(49)-7-157-22436 Fax:(49)-7-157-22437

NITTO KOHKI CO., LTD., SINGAPORE BRANCH
10 UBI CRESCENT #01-62,
UBI TECHPARK LOBBY D, SINGAPORE 408564,
Tel:(65)-6227-5360 Fax:(65)-6227-0192

NITTO KOHKI AUSTRALIA PTY. LTD.
77 Brandl St., Brisbane Technology Park,
Eight Mile Plains QLD 4113 Australia
Tel:(61)-7-3340-4600 Fax:(61)-7-3340-4640

NITTO KOHKI CO., LTD.,
BANGKOK REPRESENTATIVE OFFICE
M&A Business Center 38Q. House Convent Bldg.,
7th Floor, Unit 7A, Convent Rd., Silom, Bangrak,
Bangkok 10500 Thailand
Tel:(66)-2-632-0307 Fax:(66)-2-632-0308

NITTO KOHKI (SHANGHAI) CO., LTD.
Room1506, suite C, Orient International Plaza,
NO85 LouShanGuan Road,Shanghai, 200336, CHINA
Tel: (86)-21-6415-3935 Fax:(86)-21-6472-6957

NITTO KOHKI CO., LTD.,
SHENZHEN REPRESENTATIVE OFFICE
2005C Shenzhen ICC Tower, Fuhuasanlu 168, Futian District,
Shenzhen, Guangdong, 518048 China
Tel: (86)-755-8375-2185 Fax:(86)-755-8375-2187

EC DECLARATION OF CONFORMITY

We hereby declare that the following our product conforms with the essential health and safety requirements of EU Directives.

Product: AIR HAMMER
Model: AUTO CHISEL:A-300
Serial No: In the case of 6 digits serial number.
XXXXXXXX
Consecutive numbers (00001~99999)
Last digit (0-9) of year (A.D.)
In the case of 7 digits serial number.
XXXXXXXXX
Consecutive numbers (00001~99999)
Last two digits (00-99) of year (A.D.)

Manufacturer: NITTO KOHKI Co., Ltd.
2-9-4, Nakaikigami, Ohta-ku, Tokyo, 146-8555, Japan

Authorised person to prepare the technical construction file(TCF) in the community:
Masatoshi Ogue
President
NITTO KOHKI EUROPE Co., Ltd.
Unit21, Empire Centre, Imperial Way, Watford Hertfordshire
WD24 4TS, UK
Tel:(44)-01923-239668 Fax:(44)-01923-248815

Directive: 2006/42/EC Machinery Directive
The above product has been evaluated for conformity with above directives using the following European standards. The technical construction file (TCF) for this product is retained at the above manufacturer's location.

Machinery Directive: EN ISO12100:2010, EN ISO11148-4:2012, others
Sound Pressure/Power Level: EN ISO15744:2008, EN ISO4871:1996
Vibration Level: EN28927-9:2009

Signature: [Handwritten Signature]
Date/Place: Sep. 26. 2010 /Tokyo, Japan
Name: K.Kishi
Title: GENERAL MANAGER MACHINE TOOLS DIV.
NITTO KOHKI Co., Ltd.
2-9-4, Nakaikigami, Ohta-ku, Tokyo, 146-8555, Japan
Being the responsible person appointed and employed the manufacturer.